





**TABLE OF CONTENTS**

**TABLE OF CONTENTS**..... 2

**INTRODUCTION**..... 3

**GENERAL DESCRIPTION**..... 4

    How It Works..... 4

    Standard configurations: ..... 5

**INSTALLATION INSTRUCTIONS** ..... 6

**TECHNICAL DATA**..... 7

    Dimensions and Weight ..... 7

    Performance Curves – PRESSURE & FLOW ..... 8

    Performance Curves – Pattern Time..... 9

    Performance Curves – Jet Length..... 10

**INSTALLATION AND NORMAL OPERATION**..... 11

    General Installation Instructions ..... 11

**MAINTENANCE AND REPAIR**..... 12

**PREVENTIVE MAINTENANCE** ..... 12

**TOP ASSEMBLY** ..... 13

        Disassembly ..... 13

        Reassembly ..... 13

    Top Assembly - Exploded View Drawing ..... 14

    Impeller Housing Sub-Assembly ..... 15

        Disassembly ..... 15

        Reassembly ..... 15

    Impeller Housing Sub-Assembly – Drawing ..... 16

    Bottom Assembly ..... 17

        Disassembly ..... 17

        Reassembly ..... 17

    Bottom Assembly - Exploded View Drawing ..... 18

    Hub Sub-Assembly ..... 19

    Hub Sub-Assembly - Drawing ..... 20

    Gearbox Sub-Assembly ..... 21

    Gearbox Sub-Assembly - Drawing ..... 22

    Replacement of Ball Races..... 23

    Replacement of Ball Races - Drawing ..... 24

    Tool Listing..... 25

**TOOLS** ..... 26

**TROUBLE SHOOTING GUIDE**..... 28

**REFERENCE LIST OF PARTS**..... 29

**EXPLODED VIEW DRAWING** ..... 34

**STANDARD SPARE PART KIT**..... 36

**HOW TO ORDER SPARE PARTS AND WARRANTY CLAIM PROCEDURE**..... Error! Bookmark not defined.

    Ordering Spare Parts ..... Error! Bookmark not defined.

    Warranty Claim Procedure ..... Error! Bookmark not defined.

**SERVICE CARD**.....38

**WARRANTY CLAIM REPORT** ..... 39

**GENERAL WARRANTY** ..... 40

**INDEX**.....41



## INTRODUCTION

This manual has been prepared as a guide for the persons who will be operating and maintaining your Butterworth® tank cleaning machine. The key to long life for your tank cleaning machine will always be a system of carefully planned maintenance. Tank cleaning machines are expected to perform various types of cleaning jobs. Some applications will require that maintenance is performed more often than with less stringent applications. A properly designed and maintained CIP (Clean In Place) System is paramount to the service life of any tank cleaning machine.

**It is in your own interest to get the best and most economical performance from your tank cleaning machine. Neglect of maintenance means poor performance, unscheduled stoppages, shorter life and expense. Good maintenance means good performance; no unscheduled stoppages and better total economy.**

You will find the information contained in this manual simple to follow, but should you require further assistance, our Technical Department and worldwide net of Distributors will be pleased to help you. Please quote the type, model, and serial number with all your inquiries; this will help us to help you. The type and serial number are placed on the main body, just below the nozzle body

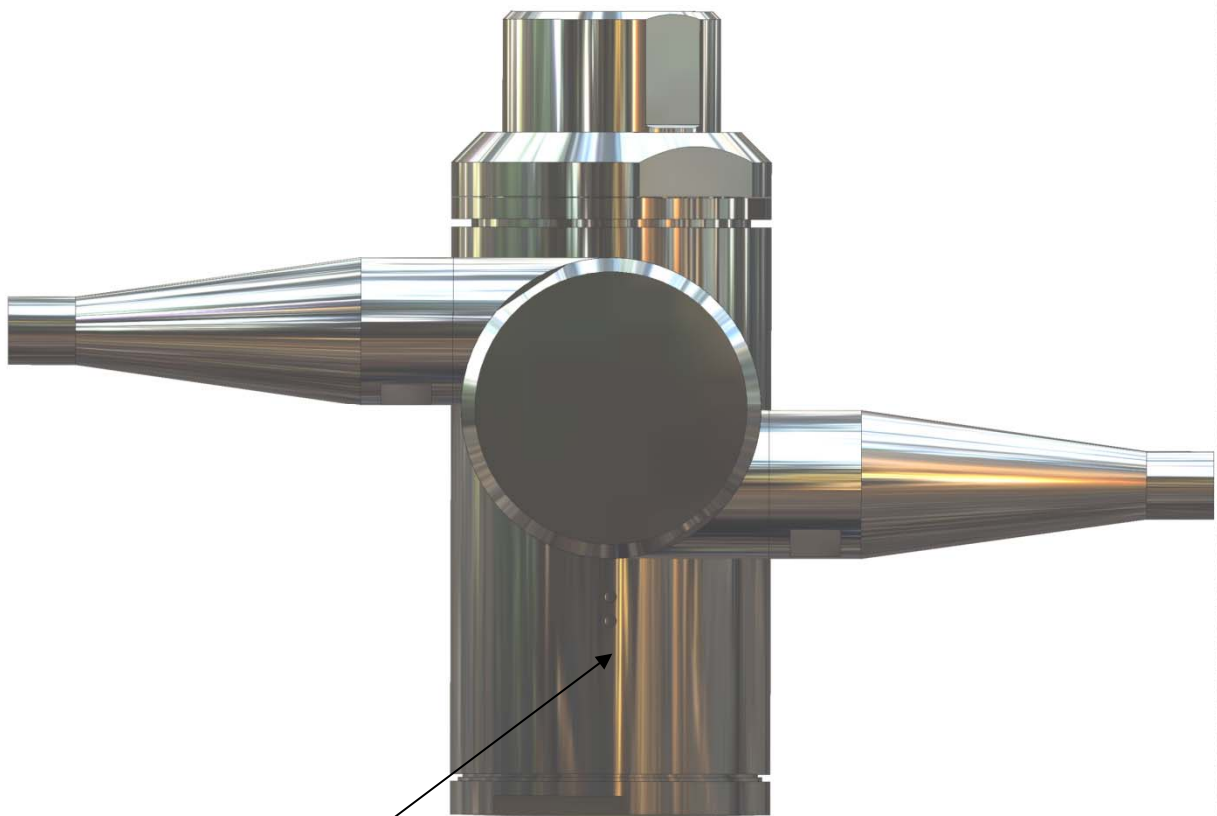

Located here.

Figure 1

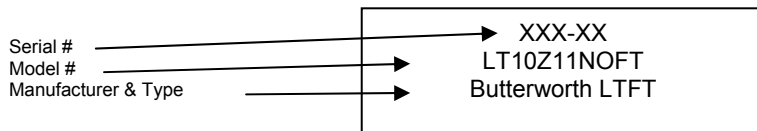



## GENERAL DESCRIPTION

The Butterworth® LTFT is a flow through gearbox tank cleaning machine that uses the fluid that flows through the machine as the lubricant.

### How It Works

The flow of the cleaning fluid into the tank cleaning machine passes through a turbine, which is set into rotation. The turbine rotation is through a gearbox transformed into a combined horizontal rotation of the body and a vertical rotation of the nozzles.

The combined motion of the machine body and the nozzle body creates a pattern matrix on the tank walls similar to the images below, keeping in mind that this pattern will propagate differently in geometries other than those shown here. In other words, the pattern would look different in a vertical cylindrical tank when compared to a horizontal cylindrical tank for a given location of the machine. The LT requires 65 axial revolutions to complete one pattern before it begins to rotate over the same location for a given coordinate within the tank. The images below show a progressive build up of the pattern matrix for a horizontal cylindrical tank. The far left image shows a course build up of the matrix, with the middle image showing a more progressive view and the far right image showing a complete pattern. The far right image is representative of the maximum density for this geometry.

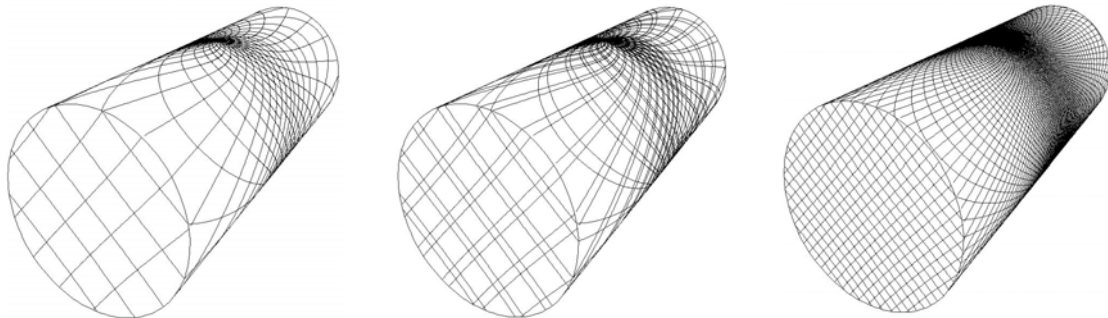

Figure 2

The speed of rotation of the turbine depends on the flow rate through the machine and the type of stator/turbine employed within the tank cleaning machine. The higher the flow rate is, the higher the speed of rotation will be; subject to the style of the guide vane (stator) and impeller (turbine) within the machine. In order to control the RPM of the machine for a wide range of flow rates, the proper machine configuration should be reviewed, relative to the cleaning application.

Apart from the jet flow through the nozzles, no other fluid by design is expelled from any other location on the machine. As this is a sealed unit; start-up rotations are higher than for media-lubricated units.



## GENERAL DESCRIPTION

### Standard configurations:

√	Model Number	Nozzles (# of Nozzles x Orifice)	Guide Vane & Impeller Configuration	Inlet	Maximum Rotational PSIG	Minimum Rotational Start-Up PSIG	Lubrication	Surface Finish (Exterior)
	LT6Z33NOFT	2 x 6.0mm	33	1.50" NPT(F)	150 PSIG	25 PSIG	Media	≥ 25 Ra μ Inch
	LT6Z33NMOFT	2 x 6.0mm	33	1.50" NPT(M)	150 PSIG	25 PSIG		
	LT6Z33BOFT	2 x 6.0mm	33	1.50" BSP(F)	150 PSIG	25 PSIG		
	LT6Z33BMOFT	2 x 6.0mm	33	1.50" BSP(M)	150 PSIG	25 PSIG		
	LT8Z21NOFT	2 x 8.0mm	21	1.50" NPT(F)	300 PSIG	50 PSIG		
	LT8Z21NMOFT	2 x 8.0mm	21	1.50" NPT(M)	300 PSIG	50 PSIG		
	LT8Z21BOFT	2 x 8.0mm	21	1.50" BSP(F)	300 PSIG	50 PSIG		
	LT8Z21BMOFT	2 x 8.0mm	21	1.50" BSP(M)	300 PSIG	50 PSIG		
	LT10Z11NOFT	2 x 10.0mm	11	1.50" NPT(F)	300 PSIG	35 PSIG		
	LT10Z11NMOFT	2 x 10.0mm	11	1.50" NPT(M)	300 PSIG	35 PSIG		
	LT10Z11BOFT	2 x 10.0mm	11	1.50" BSP(F)	300 PSIG	35 PSIG		
	LT10Z11BMOFT	2 x 10.0mm	11	1.50" BSP(M)	300 PSIG	35 PSIG		
	LT10Z21NOFT	2 x 10.0mm	21	1.50" NPT(F)	150 PSIG	25 PSIG		
	LT10Z21NMOFT	2 x 10.0mm	21	1.50" NPT(M)	150 PSIG	25 PSIG		
	LT10Z21BOFT	2 x 10.0mm	21	1.50" BSP(F)	150 PSIG	25 PSIG		
	LT10Z21BMOFT	2 x 10.0mm	21	1.50" BSP(M)	150 PSIG	25 PSIG		
	LT12Z11NOFT	2 x 12.0mm	11	1.50" NPT(F)	300 PSIG	30 PSIG		
	LT12Z11NMOFT	2 x 12.0mm	11	1.50" NPT(M)	300 PSIG	30 PSIG		
	LT12Z11BOFT	2 x 12.0mm	11	1.50" BSP(F)	300 PSIG	30 PSIG		
	LT12Z11BMOFT	2 x 12.0mm	11	1.50" BSP(M)	300 PSIG	30 PSIG		

Table 1

**Note:**

**Maximum Rotational PSIG:**

**If the maximum rotational PSIG is exceeded, reduced runtime between maintenance intervals will also be reduced. This is a result of increased RPM load from the turbine.**

**Minimum Rotational Start-Up PSIG:**

**Based on new machine conditions and/or newly refurbished conditions.**

This machine is equipped with a clutched hub. Care should be taken when installing and removing the machine to insure that the nozzles are not inadvertently hit or knocked with any hard blows, as this would transmit forces on the gearing that is best avoided to insure long life and reduced wear.

**(Note: Optional configurations are available as non-standard products by contacting your nearest agent or distributor.)**

## INSTALLATION INSTRUCTIONS

Never attach the LTFT by grabbing the nozzles to Tighten the machine onto the connection (Figure 3). The Proper way to attach the LTFT can be seen in Figure 4.



Figure 3

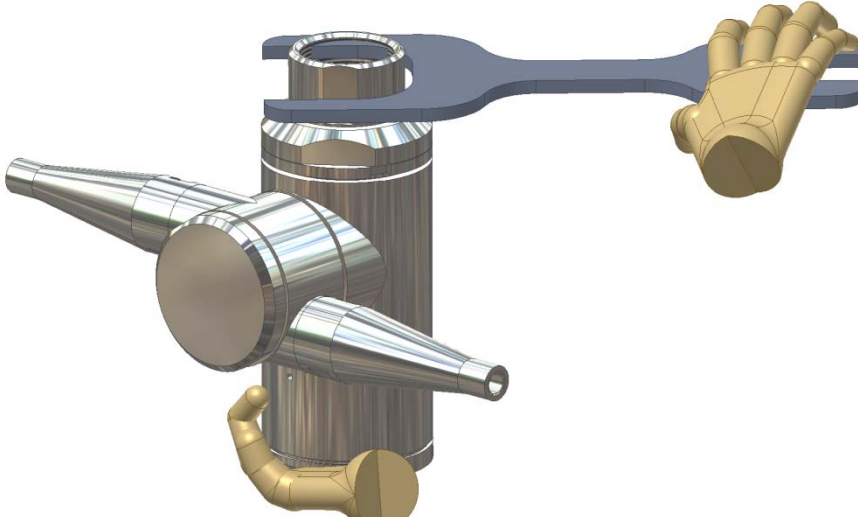

Figure 4

The nature of stainless steel against itself can cause galling. When threading the inlet connection onto your fluid connection, it is recommended that you employ either Teflon tape or another appropriated anti-seizing compound to avoid this event. See comments on conductivity; page 11.

The following product is recommended:

Technical Data Sheet

**LOCTITE® Food Grade Anti-Seize**

March 2006

<b>PRODUCT DESCRIPTION</b>	LOCTITE® Food Grade Anti-Seize provides the following product characteristics:	<b>Directions for use</b>
<b>Appearance</b>	White paste	1. For best performance the mating surface should be clean and free of grease.
<b>Color</b>	White	2. Apply this coating to threads and flats of nuts and bolts, washers.
<b>Consistency</b>	Thick	3. Use full strength. Do not thin.
<b>Finish</b>	Smooth	
<b>Material</b>	Stainless steel, aluminum, brass, copper, steel, titanium, Inconel, Hastelloy, Monel, and other general purpose materials.	<b>Loctite Material Specifications</b>
<b>Material</b>	Stainless steel, aluminum, brass, copper, steel, titanium, Inconel, Hastelloy, Monel, and other general purpose materials.	1. For best performance the mating surface should be clean and free of grease.
<b>Material</b>	Stainless steel, aluminum, brass, copper, steel, titanium, Inconel, Hastelloy, Monel, and other general purpose materials.	2. Apply this coating to threads and flats of nuts and bolts, washers.
<b>Material</b>	Stainless steel, aluminum, brass, copper, steel, titanium, Inconel, Hastelloy, Monel, and other general purpose materials.	3. Use full strength. Do not thin.

**LOCTITE® Food Grade Anti-Seize** prevents seizing, galling, welding, and wear on threaded parts and other metal-to-metal surfaces. It is a combination of white lubricating solids and extreme pressure lubricating agents in an aluminum based white oil. Typical applications include pipe joints, nuts, bolts, and other fasteners, shafts, pistons and tapered shafts, and metal-to-metal contact involving stainless steel and other materials. It is used in industrial food industries such as meat and dairy processing plants, other products processing plants, canning, dairy, grain processing plants, sugar processing plants, bakeries, confectionery plants, breweries, hospitals, and other general plant maintenance. This product is typically used in applications with an operating range of -20 °C to +140 °C.

**NSF International**  
 Registered to NSF Category #1 for use as a lubricant with restricted food contact in and around food processing areas.

**TYPICAL PROPERTIES OF UNCURED MATERIAL**

Flash Point (ASTM D56)	> 100 °C
Freeze Point (ASTM D56)	< -20 °C

**GENERAL INFORMATION**  
 This product is not recommended for use in pure oxygen and should not be used in applications where it may be subjected to a pressure for recovery or other safety-critical situations. For safe handling information on this product, consult the Material Safety Data Sheet (MSDS).

**Notes:**  
 The data contained herein are furnished for information only and are subject to change without notice. The user assumes responsibility for the results obtained by others who utilize methods not listed herein and is not held responsible to determine suitability for the user's purpose of any production methods mentioned herein and to adjust such information as applies any hazards that may be involved in the handling and use thereof. Loctite Corporation, Herndon, Virginia, USA, specifically disclaims all warranties expressed or implied, including warranties of merchantability or fitness for a particular purpose, arising from this data sheet or any other Loctite Corporation's products. Herndon Corporation specifically

### Loctite Product Numbers:

- 51168: Food Grade Anti-Seize; 8 oz. brush top
- 51170: Food Grade Anti-Seize; 2 lb. can
- 51171: Food Grade Anti-Seize; 40 lb. pail



## TECHNICAL DATA

### Dimensions and Weight

Weight of machine	:	14 lbs (6.35 kgs)
Working pressure	:	0-300 PSIG (0-21 Bar)
Working temperature max.	:	300° F (95° C) Standard Configuration
Materials Of Construction	:	See exploded view drawing (page 34)

### Principal dimensions in inches and [mm]:

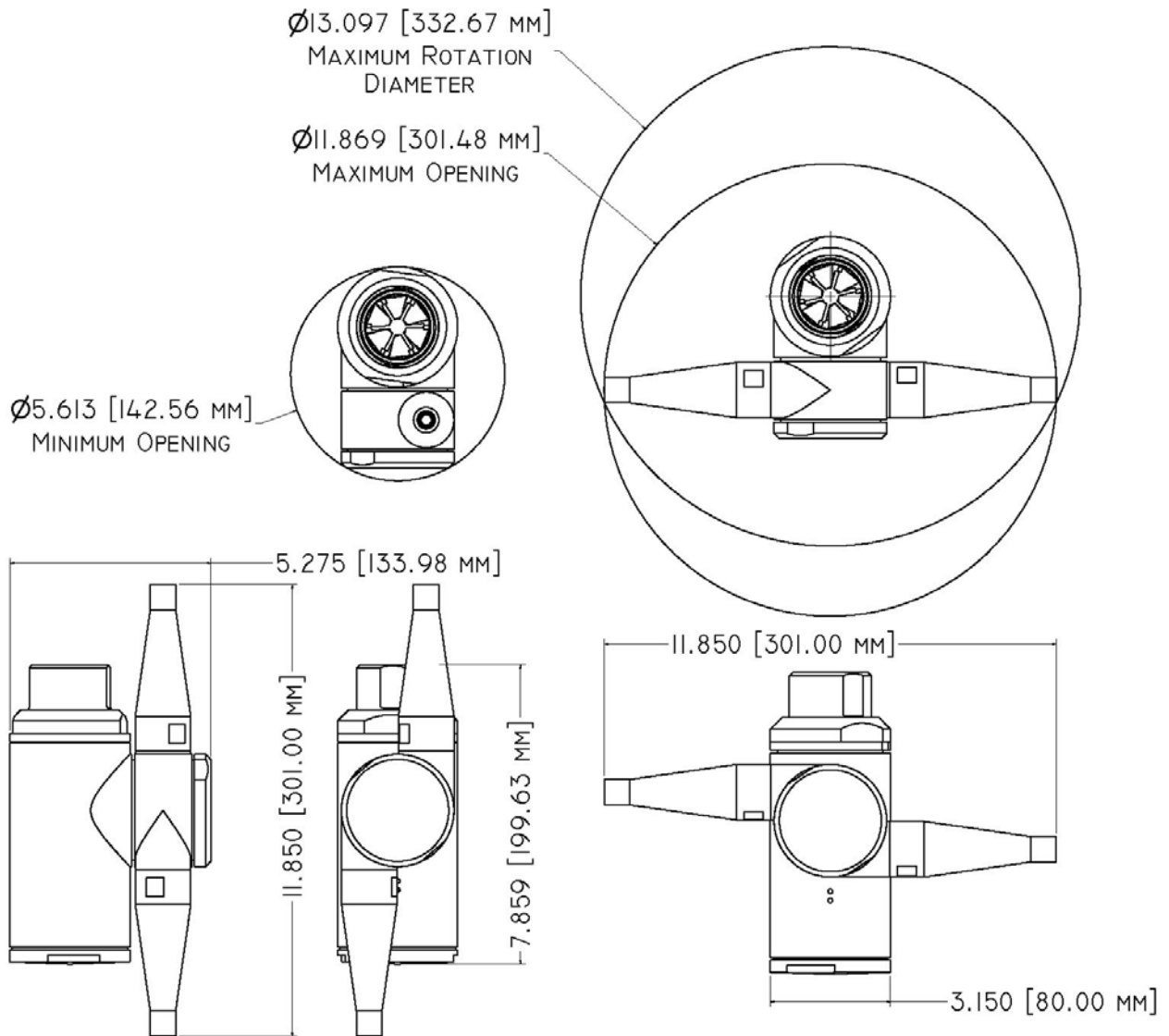

Figure 5



**TECHNICAL DATA**

**Performance Curves – PRESSURE & FLOW**

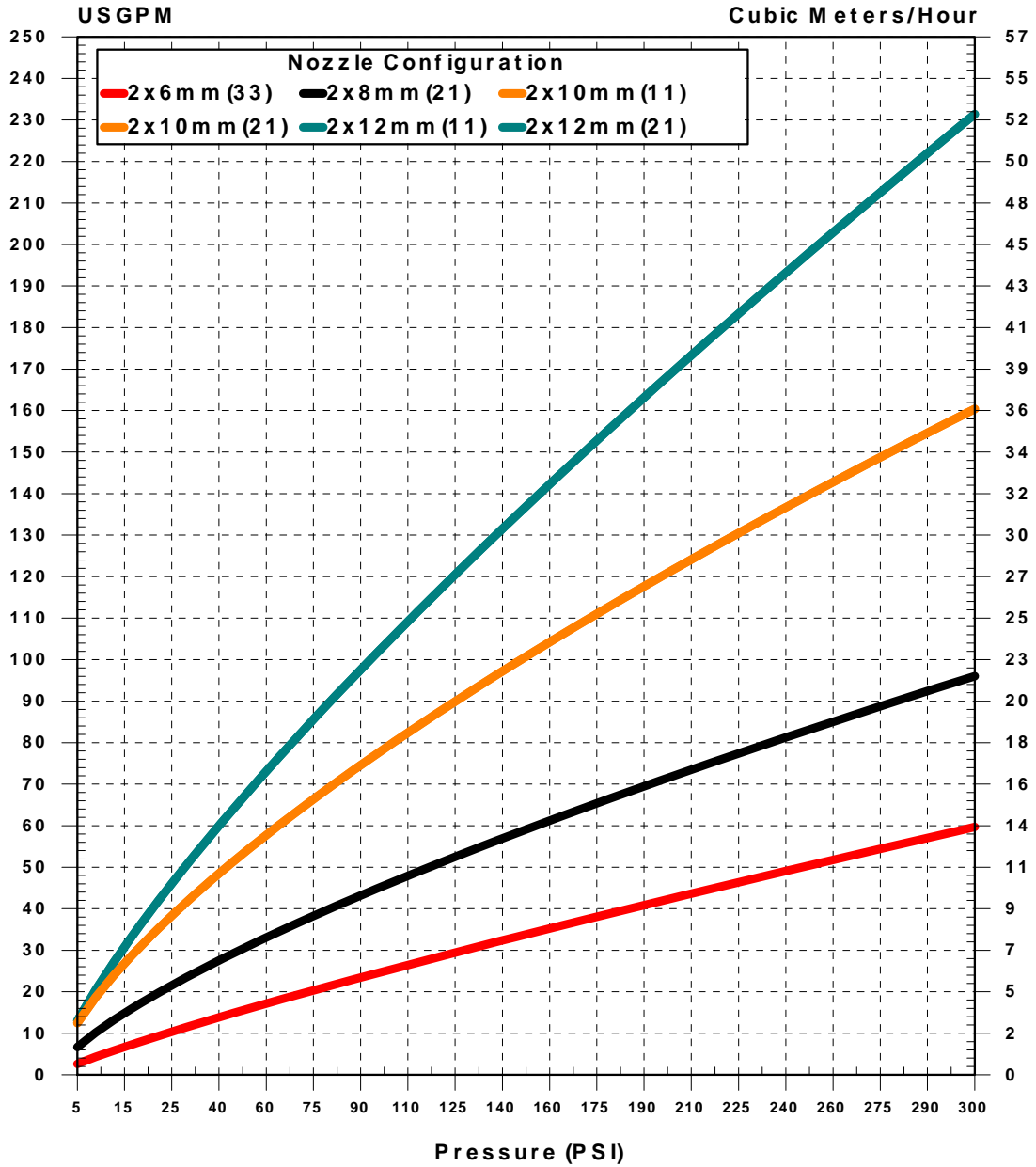

Figure 6

Related as number of nozzles x orifice and guide vane/turbine configuration.  
 For Example: 2x8 (21) is: 2 nozzles at 8mm each with a type 2 guide vane and type 1 impeller



## TECHNICAL DATA

### Performance Curves – Pattern Time

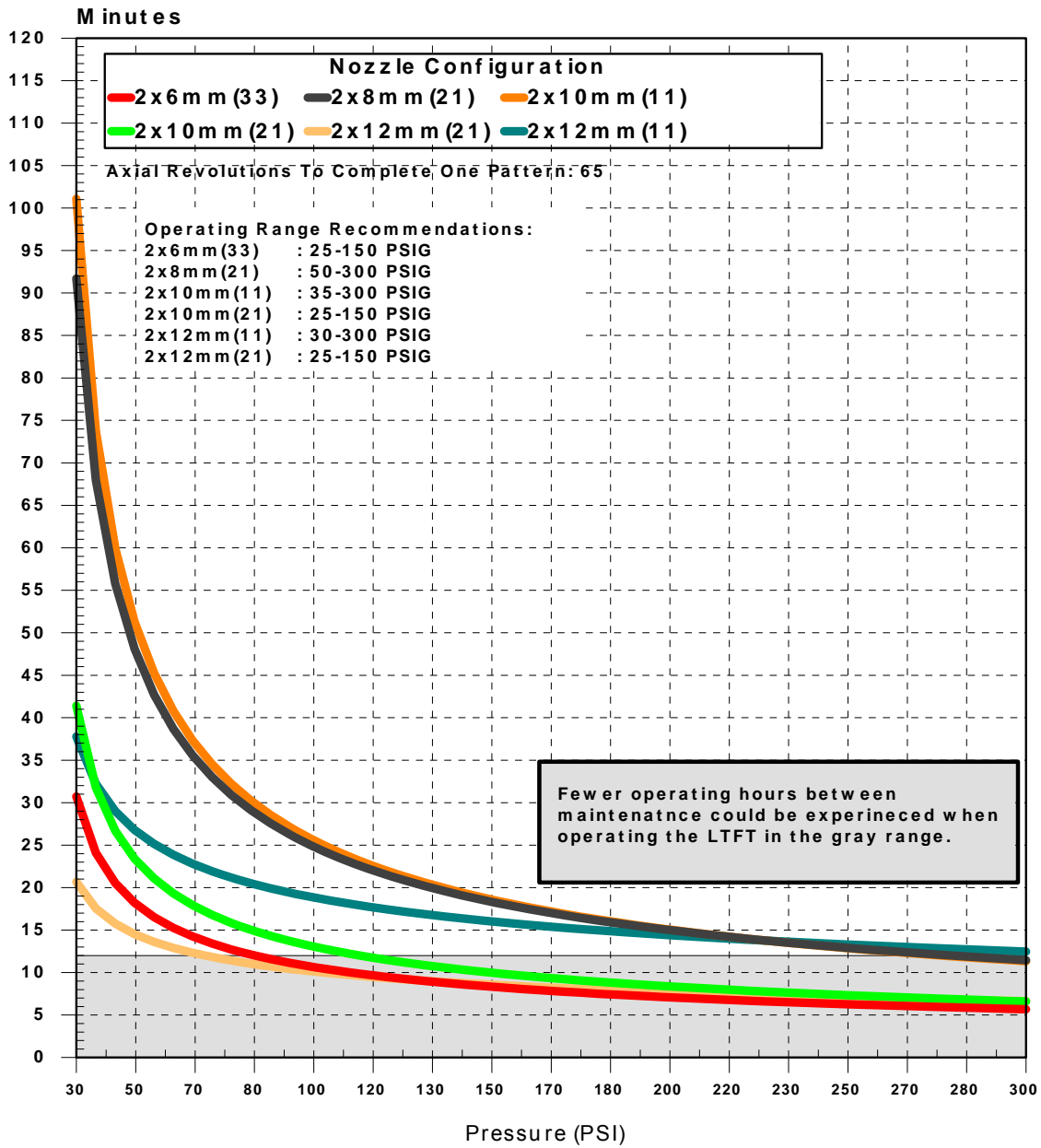

Figure 7

Note: The pattern time related in these curves is the time required to make 65 axial revolutions. Pattern time is not indicative of the time required to perform the required cleaning. Depending upon the application, the number of pattern completions will vary for the relative cleaning application. See Table 1 on page 5



### TECHNICAL DATA

### Performance Curves – Jet Length

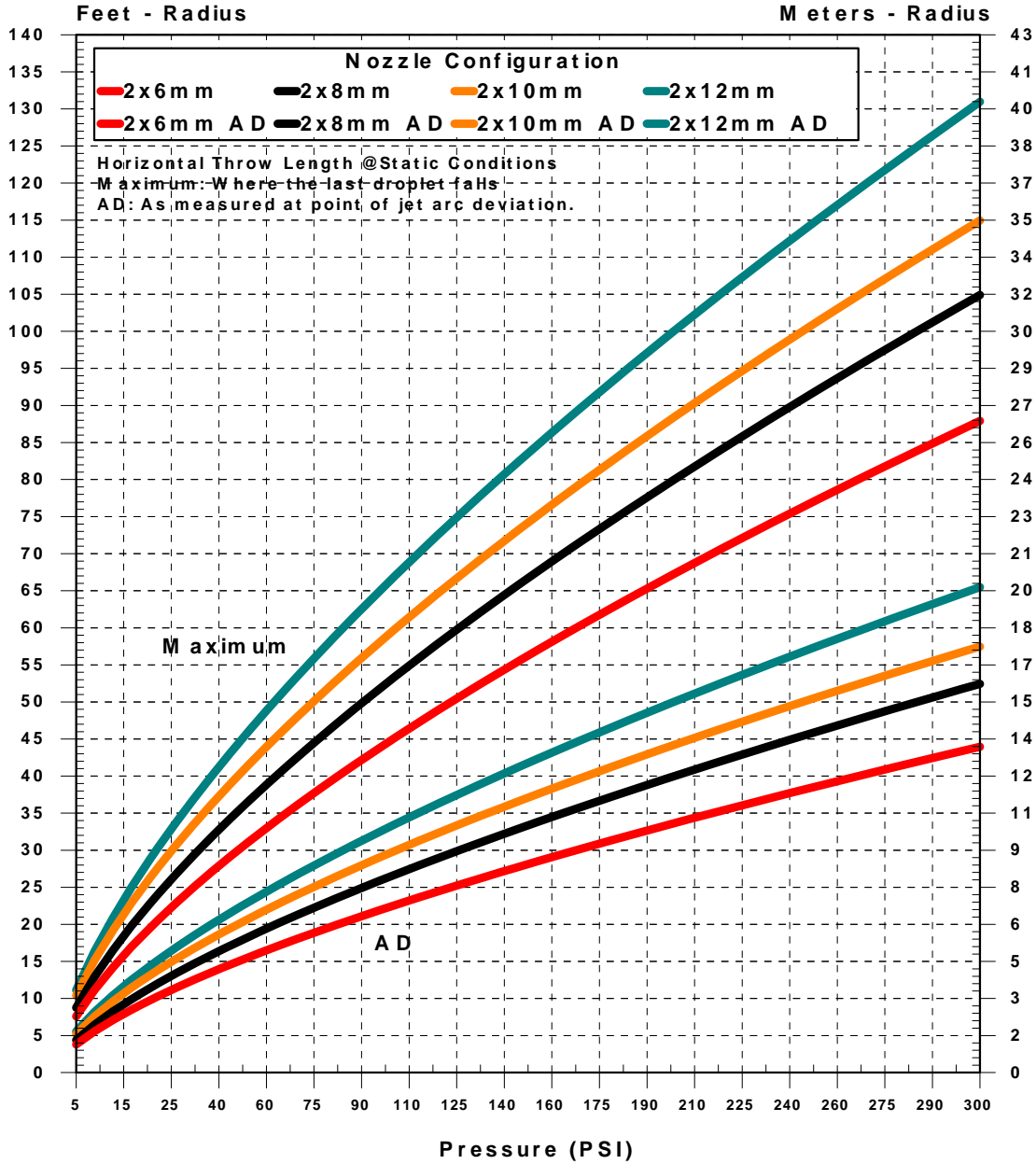
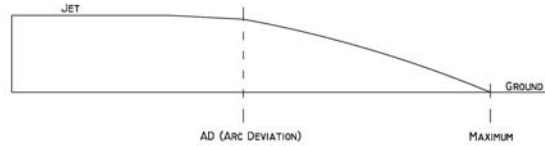

Figure 8

Maximum jet-length on this curve is measured at static conditions and where the last droplet falls. The effective range is subjective to the cleaning requirement. However in this curve effective is at the point of arc deviation. Throw lengths are measured as horizontal throw length at static condition. Vertical throw length upwards is approximately 1/3<sup>rd</sup> less. Effective throw length varies depending on jet peripheral speeds over the surface, substance to be removed, cleaning procedure and cleaning agent. The inlet pressure has been taken immediately before the machine inlet. To achieve the performance indicated in the curves, allowance must be made for pressure drop in the supply lines between pump and machine.



Operators Manual Model : LTFT  
Manual No. : 202.2008.01.14  
Release Date : JUNE 1, 2008

## INSTALLATION AND NORMAL OPERATION

### General Installation Instructions

The Butterworth® tank cleaning machine should be installed in vertical position (upright or inverted). It is recommended to install a filter in the supply line in order to avoid large particles lodging inside the machine. Before connecting the machine into the system, all supply lines and valves should be flushed to remove foreign matter.

### Recommended filtration: 100-200 micron

**Warning: If the machine is used in potential explosive atmospheres, tapes or joint sealing compounds, which are electrical insulators, must not be used on threads or joints. In addition, connecting pipe work must be electrically conductive and grounded to the tank structure. This is essential to avoid the build-up of static electricity on the machine.**

The Butterworth® tank cleaning machine as delivered has been tested at the factory before shipping.

### Normal Operation

**Cleaning Media:** Use only media compatible with the materials as listed on the reference list of parts as indicated for your model; see page 29.

**After Use Cleaning:** Depending on the type of cleaning that is being performed and the type of cleaning solution used, a procedure for after use flushing of the cleaning system should be developed for your application. In general, a fresh water flush is recommended after each cleaning.

**Pressure:** Avoid Hydraulic shocks. Increase pressure gradually; ramping up the pressure over 5-7 seconds. Do not exceed 300 PSI (21 Bar) inlet pressure. High pressure in combination with high flow rate will increase consumption of wear parts and should be expected when compared to operations at lower pressures and flow rates.



## MAINTENANCE AND REPAIR

### PREVENTIVE MAINTENANCE

In order to keep your Butterworth® tank cleaning machine servicing you as an efficient tool in your tank cleaning operations, it is essential to maintain its high performance by following a simple preventive maintenance program, which will always keep your tank cleaning machine in good condition.

**Good maintenance is careful and regular attention!**

The following recommended preventive maintenance program is based on tank cleaning machines working in average conditions. However, you will appreciate that a tank cleaning machine, which has a rough and dirty job to do, will need more frequent attention than one working in ideal conditions. We trust that you will adjust your maintenance program to suit.

Always use **only** proper tools. Use Butterworth® standard tool kit (page 26) . Never force, hammer or pry components together or apart. Always perform all assembly/disassembly steps in the order described in this manual. Never assemble components without previous cleaning. This is especially important at all mating surfaces. Work in a clear well lit work area.

#### Every 400 working hours

1. Disassemble machine as described on the following pages leaving the gearbox intact; (position 37).
2. Thoroughly flush the machine prior to disassembly and insure that no hazardous material remains in the machine.
3. Upon complete disassembly of the machine; (except for position 37), all parts should be thoroughly washed and/or degreased in the appropriate manner, then inspected accordingly.
4. Inspect seals and bushings for wear; locate position numbers from the exploded view drawing on page 34 and bill of materials on page 29. Replace if unduly worn.
5. Inspect bevel gears located at position numbers 12.6 and 18. Replace if unduly worn.
6. Inspect gearbox rotation by inserting position 37 into position 32.3 and rotate either direction. If rotation is not consistent and smooth, then inspection of gears should be undertaken and replaced where necessary. For representation of gear timing, see Figure 20.
7. A service card is included with this manual; (see page 38). This should be completed each time service is performed on your tank cleaning machine so that a proper record/history is maintained.



## MAINTENANCE AND REPAIR

### TOP ASSEMBLY

#### Disassembly

1. Secure tank cleaning machine in vice; using soft jaws to avoid damaging the finish.
2. Remove position 1 by rotating clockwise while holding inlet ring; position 12.4 using spanner wrenches as shown in Figure 26 and Figure 28. Also see Figure 9.
3. Remove position 2 by hand and slightly tapping with a rubber mallet from side to side.
4. Remove position 3 and 4.
5. Remove position 5.1 by prying out with a screw driver inserted under the vanes.
6. Remove position 8.1, 8.2, 8.3, and 8.4 as an assembly by lifting on position 8.1 and by hand. In some cases it may be necessary to pry this out with a screwdriver inserted under the vanes of position 8.1
7. Remove position 8.2 using snap-ring pliers (see Figure 25 on page 26)
8. Remove position 8.1 from 8.4 by manually pulling position 8.1 from 8.4. On occasion, it may be necessary to tap position 8.4 from position 8.1.
9. Remove position 8.3 from 8.4.

#### Reassembly

1. Reverse the procedure described in the disassembly process above.
2. It is advised to include the use of Anti-Seize as described on page 6 when connecting position 1 to position 12.4.

## MAINTENANCE AND REPAIR

### Top Assembly - Exploded View Drawing

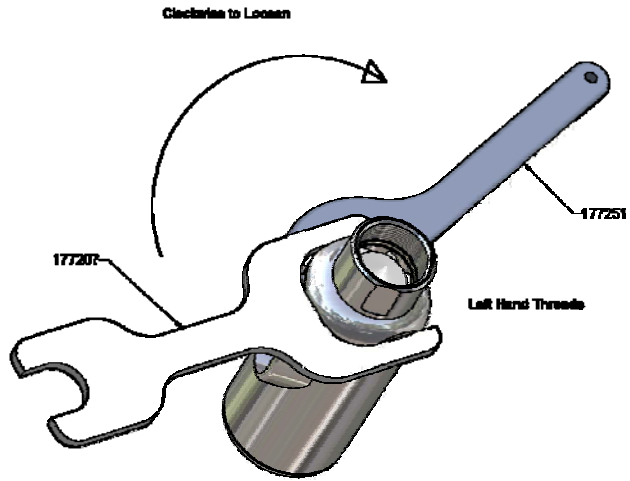

Figure 9

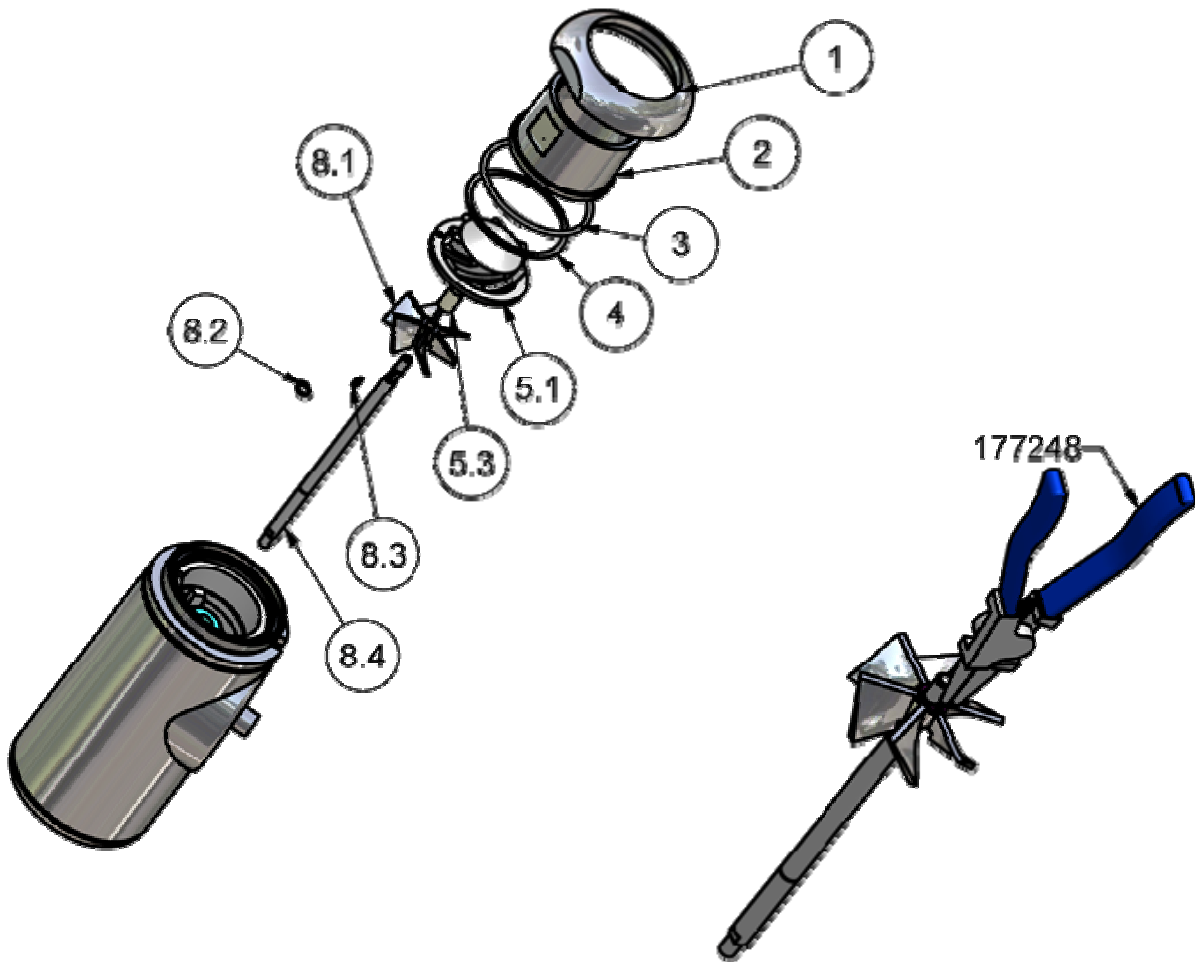

Figure 10



## MAINTENANCE AND REPAIR

### Impeller Housing Sub-Assembly

#### Disassembly

1. Remove position 9 using snap-ring pliers (see Figure 22).
2. Remove with needle nose pliers (see Figure 29) position 10 from position 12.
3. Remove position 12 from position 15 using two regular screwdrivers by prying position 12 from position 15 using the upper lip of position 15 as a pivot point or screw the screw cap; position 1 back on with inlet; position 2 and pull the impeller housing assembly; position 12 from the main body; position 15.
4. Remove position 13 from position 12.
5. Remove position 33 using needle nose pliers (see Figure 29) from position 32.2.
6. Using a punch (see Figure 24) remove position 12.5 by tapping position 12.5 with the punch and hammer driving inward.
7. On completion of step 5 above remove positions 12.6 from 12.1 along with removing positions 12.1, 12.2, and 12.3. These items should be removable by hand or with a small regular screwdriver.

#### Reassembly

1. Reverse the above procedure in the steps mentioned.

## MAINTENANCE AND REPAIR

### Impeller Housing Sub-Assembly – Drawing

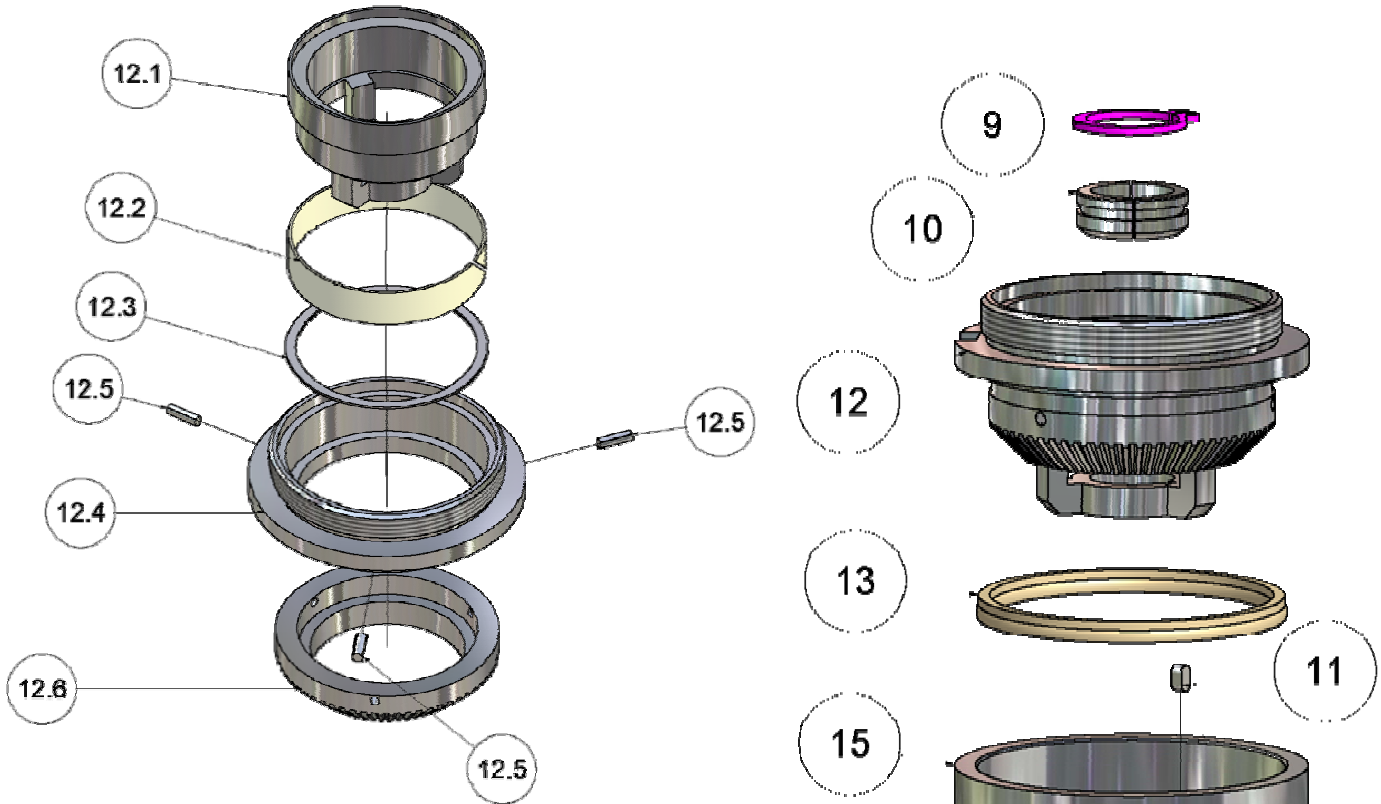

Figure 13

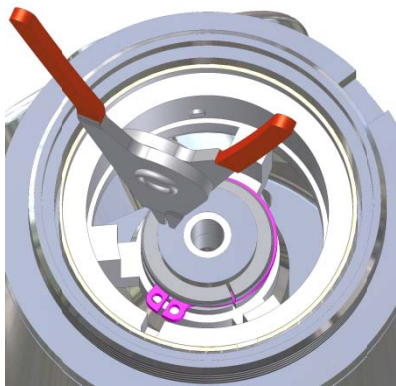

Figure 11

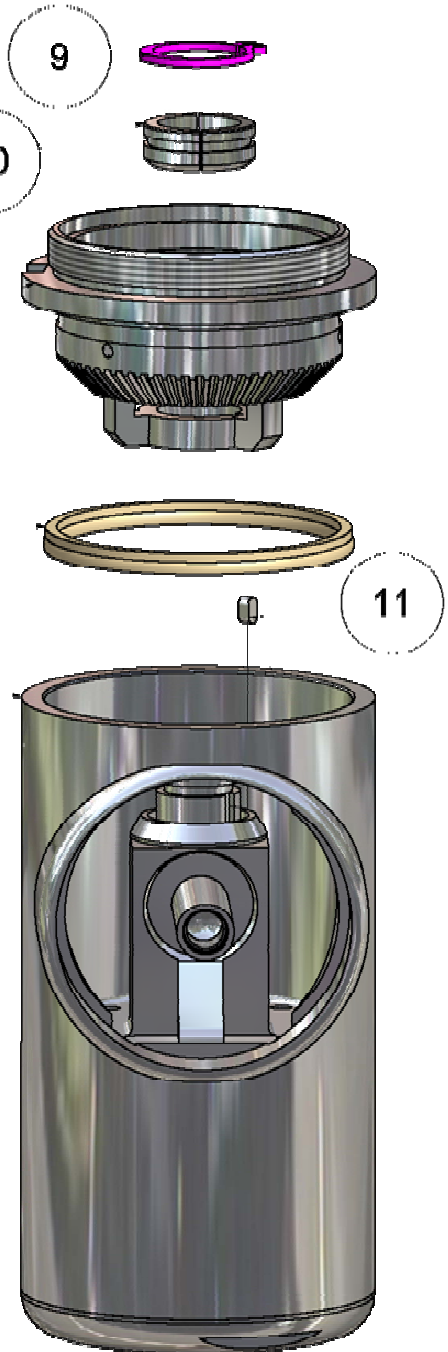

Figure 12



## MAINTENANCE AND REPAIR

### Bottom Assembly

#### Disassembly

1. Invert body and place in vice (with soft jaws) and remove position 41.3 from position 15 by rotating position 41.3 clockwise (these are left-hand threads); using torque cap tool (see Figure 30). Alternately, you can use the spanner wrench (see Figure 26).
2. Remove position 40 from atop position 37 (this will be loose and should be free after completing step 1).
3. Remove position 8.5 from position 39 by hand or with needle nose pliers (see Figure 29).
4. Remove position 39 from position 37. This should come off by hand; but use of needle nose pliers as previously mentioned may be necessary.
5. Ball race removal; position 41.1 is discussed on pages 23 and 24
6. Remove position 38 using snap-ring pliers (Figure 27) from position 32.3 and as shown in Figure 16.
7. Remove position 37 from position 32.3 using two regular screwdrivers and prying it loose from position 15, using the upper edge of position 15 as the pivot point.
8. Remove position 36 from inside of position 32.3
9. Remove position 32.3 from position 15.
10. To disassemble the main stem; position 32.3; remove pins; position 32.3c by punching the pins inward until they are free of position 32.3b. After this step, remove position 32.3b from 32.3a by tapping position 32.3a from 32.3b using a soft mallet and positioning position 32.3b in a vice on the lip of 32.3b.
11. Remove position 31 from position 30; this should be loose and is removable by hand.
12. For position 30 and 32.1, ball race removal; see pages 23 and 24.
13. Remove positions 32.2 and 32.4 by inserting a hooked probe past these positions and then pulling these positions out of position 32.3.
14. Remove position 29 from position 15 by hand or with a punch by inverting position 15 and tapping on the ledge of position 29.

#### Reassembly

1. Reverse process as stated above with the additional observance of using a torque wrench as shown Figure 14 to attach position 41.3 to position 15.
2. See Figure 20 for gear alignment instructions when placing position 37 back into position 32.3.

## MAINTENANCE AND REPAIR

### Bottom Assembly - Exploded View Drawing

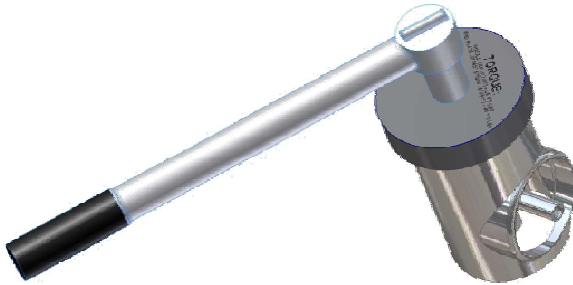

Figure 14

Note: This is a left-hand thread

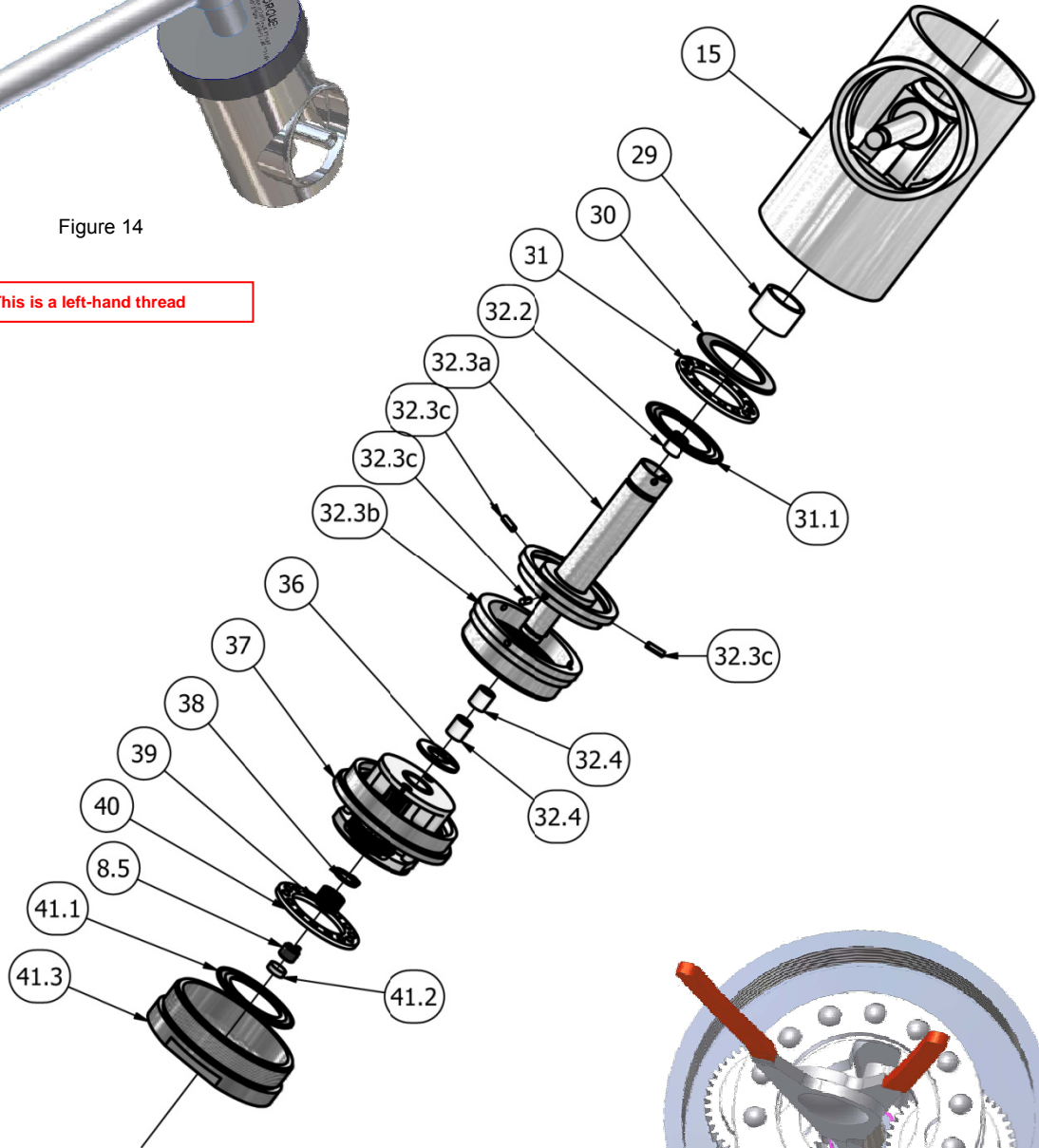

Figure 15

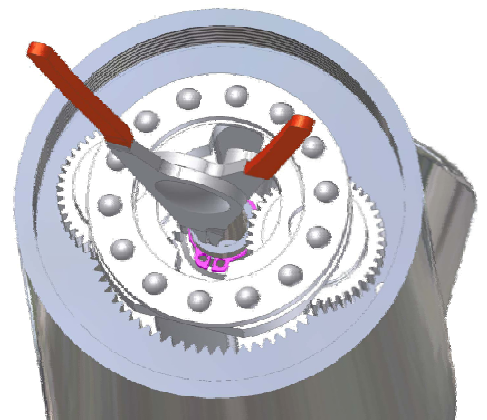

Figure 16



## MAINTENANCE AND REPAIR

### Hub Sub-Assembly - Drawing

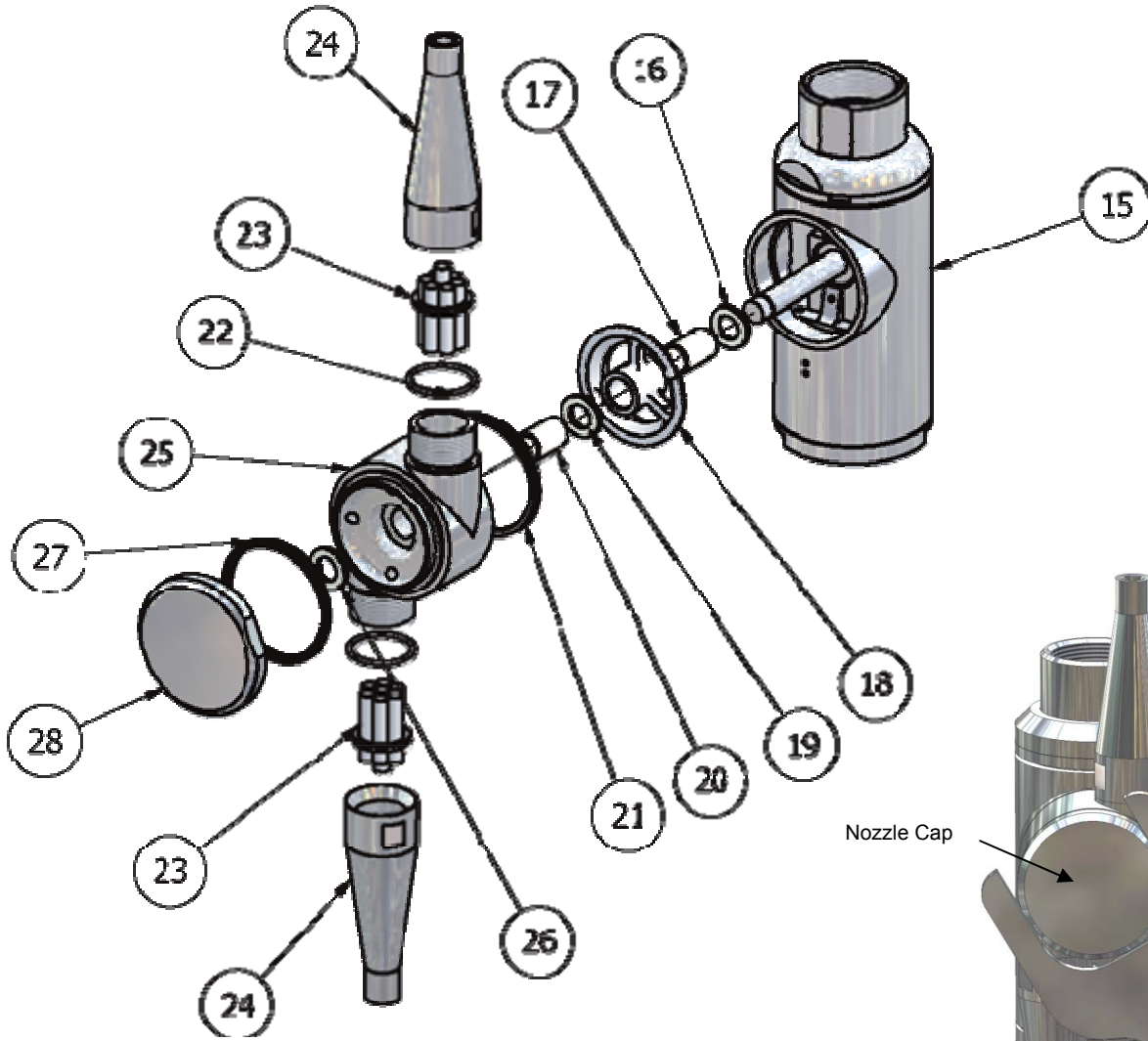

Figure 18

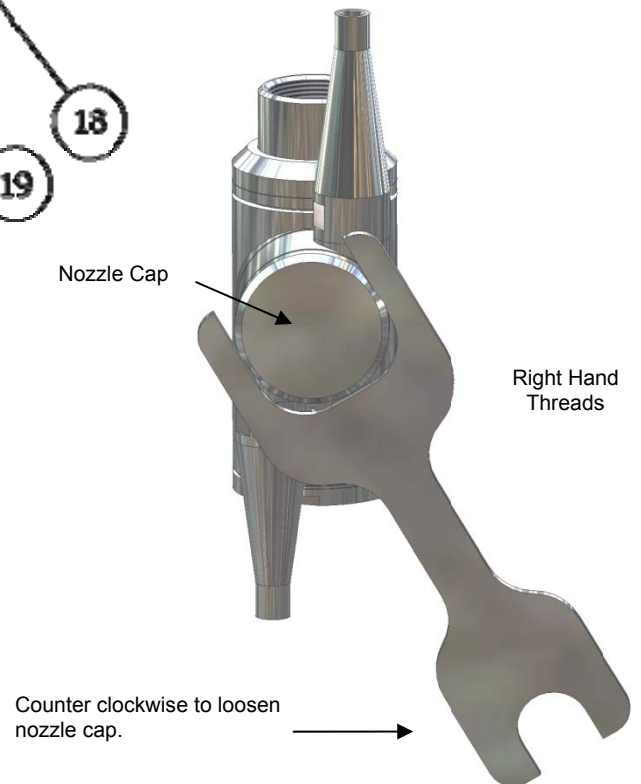

Figure 17



## MAINTENANCE AND REPAIR

### Gearbox Sub-Assembly

#### Disassembly

1. Remove position 37.3 from position 37.4.
2. Remove position 37.9 from position 37.4 using tool in Figure 23.
3. Remove position 37.10 from position 37.4 using tool in Figure 23.
4. Remove 37.8 from 37.4 by using tool in Figure 23. Tap gently so as not to damage.
5. Remove position 37.2 from position 37.5 by hand.
6. Remove 37.5 from 37.4 by hand.
7. Remove 37.6 and 37.7; these will be loose and removable by hand.

#### Reassembly

1. Reverse the above procedure and be sure to time the gears as indicated in Figure 20.

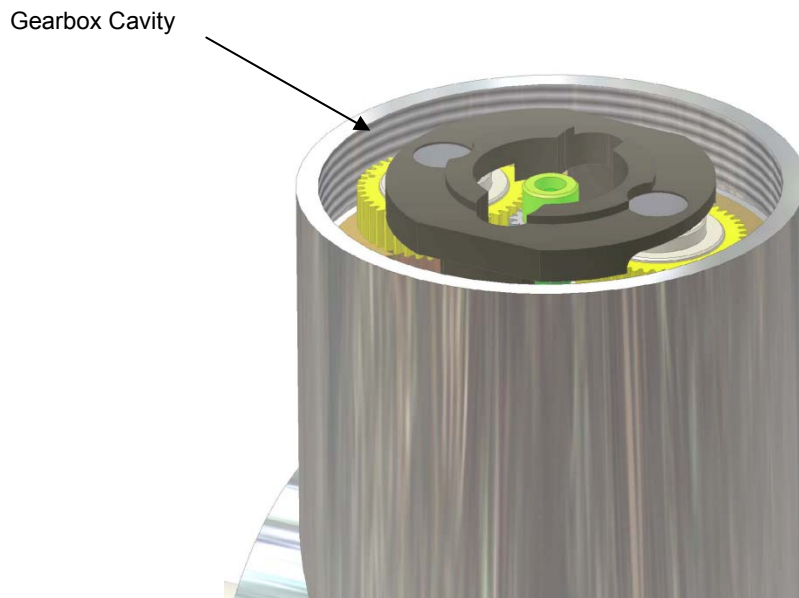

Figure 19

## MAINTENANCE AND REPAIR

### Gearbox Sub-Assembly - Drawing

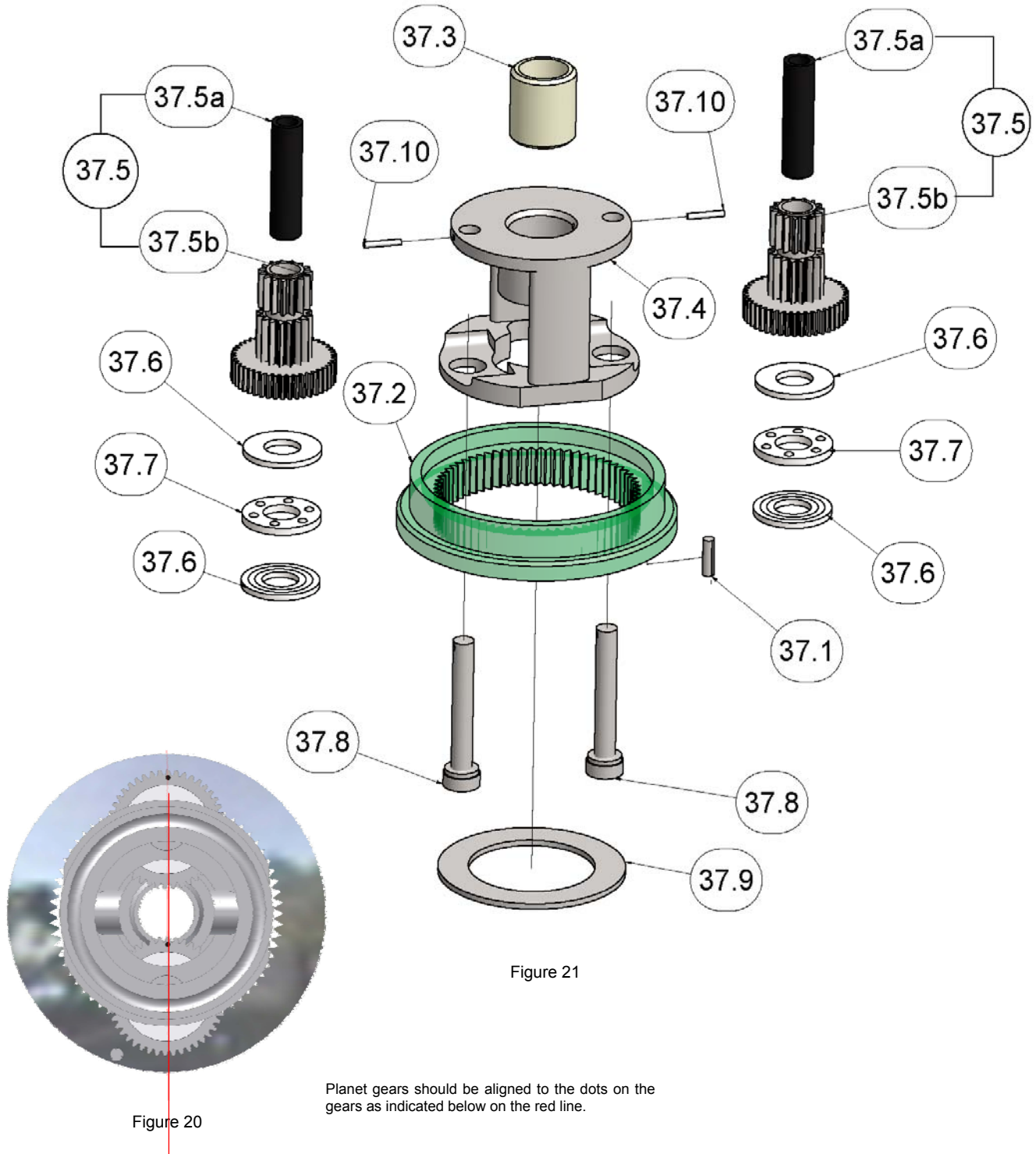

Figure 21

Planet gears should be aligned to the dots on the gears as indicated below on the red line.

Figure 20



## MAINTENANCE AND REPAIR

### Replacement of Ball Races

Referring to the images on page 24, ball races are employed in a number of positions within this tank cleaning machine. To remove the ball race, a screwdriver can be placed on the inside edge or outer edge of the race (depending on which race is being removed). There is slight bevel on the races edge that will allow for the race to be cantilevered out of position.

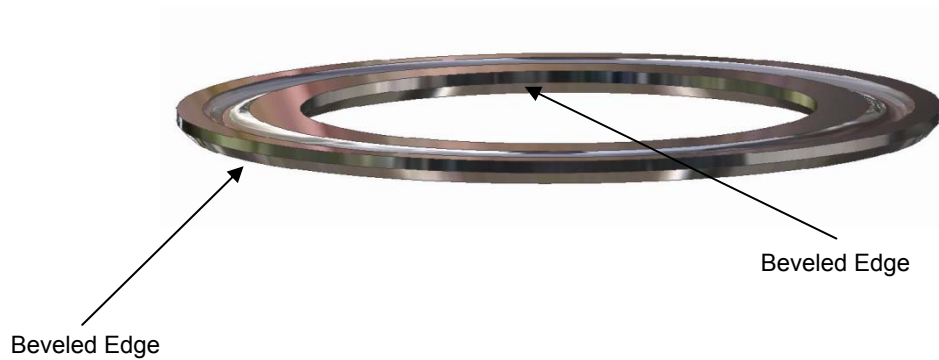



## MAINTENANCE AND REPAIR

### Replacement of Ball Races - Drawing



Pos. 37.4 & 37.9



Pos. 41.3 & 41.1

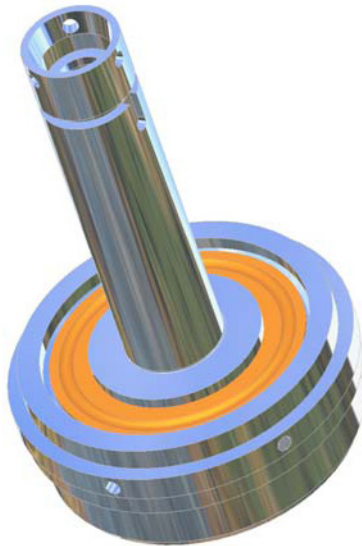

Pos. 32.3 & 32.1

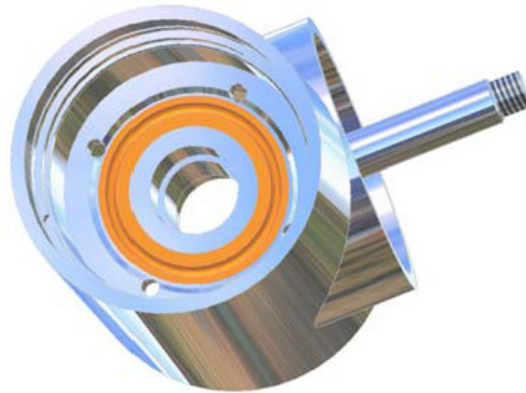

Pos. 15 & 30



## MAINTENANCE AND REPAIR

### Tool Listing

LTFT Tool Kit Part Number: 5699

Consisting of:

1. 1 each 177207 Spanner Wrench; see Figure 26.
2. 1 each 177245 Circlip Pliers; not shown.
3. 1 each 177246 3mm Punch; see Figure 24.
4. 1 each 177247 1.5mm Punch; see Figure 23.
5. 1 each 177248 5mm Circlip pliers; straight nose; see Figure 25.
6. 1 each 177249 10-20mm Circlip pliers; see Figure 22.
7. 1 each 177250 Pointed nose pliers; see Figure 29.
8. 1 each 177251 3 inch hook spanner; see Figure 28.
9. 1 each 177254 3-10mm circlip pliers; straight nose; Figure 27.
10. 1 each 177255 Torque socket tool; see Figure 30.
11. 1 each 177253 Main stem insertion tool; not shown
12. 1 each 177252 Seal insertion tool; not shown
13. 1 each 177227 Drive shaft insertion tool; not shown





## TOOLS



Figure 26

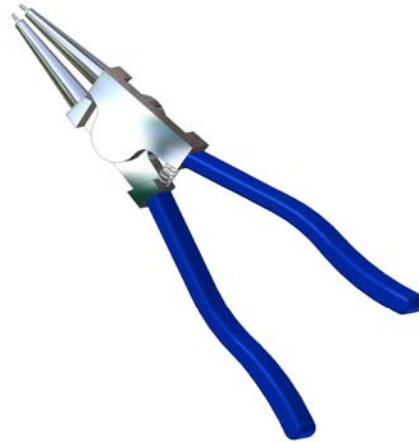

Figure 25



Figure 24



Figure 23



Figure 22



## TOOLS



Figure 28

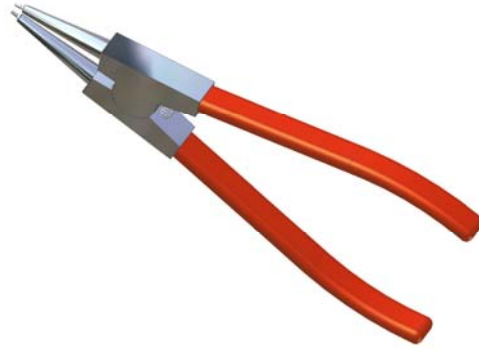

Figure 27



Figure 29



Figure 30



## TROUBLE SHOOTING GUIDE

Symptom: Tank cleaning machine will not rotate.

Possible causes are:

1. No or insufficient liquid flow
  - a. Check fluid supply to insure that pressure and flow as per the operating curves are being observed. For this to be properly accomplished, you should install a pressure gauge as close to the machine inlet as possible. In any case the pressure gauge should not be any further from the tank cleaning machine than 15 feet.
2. Tank cleaning machine inlet is blocked.
  - a. Check inlet of machine; (position 2); and insure that no debris or foreign matter is present. Remember that it was advised earlier in this manual to employ a 100 micron filter.
3. Tank cleaning nozzles are blocked.
  - a. Remove the nozzles; (position 24) and check for any foreign matter. If present, remove and then replace nozzles.
4. Bevel gears are blocked.
  - a. If foreign matter has entered the machine and passed through the body, it may have lodged itself in the bevel gears; position 12.6 and 18. To check these areas refer to Figure 18 for instructions on removal of the hub. Take care to review the gearing and ensure that there is no damage that could prevent operation.
5. Impeller rotation is restricted.
  - a. If foreign matter has passed through the inlet and past the guide vane; (position 5.1) you would not be able to see that matter by looking into the inlet. To check for blockage here; see Figure 10 and disassemble as required to perform your inspection.
6. Gearbox rotation is restricted.
  - a. If foreign matter has entered into this area; (position 37); to perform an inspection see Figure 14 and Figure 15 for disassembly instructions.
7. Worn parts; replacements required.
  - a. After items 1-6 above have been checked; it may be necessary to replace parts due to normal wear associated with your type of operation. One of the best ways to determine the need to replace parts is a visual inspection of the primary wear parts as listed in the reference list of parts on page 29. Additionally, the working mechanism of the machine can be checked by rotating the impeller; (position 8.1). By rotating this position, the turbine shaft and various gearing within the tank cleaning machine is engaged. Rotation should be smooth and consistent. If that is not the case then parts replacement is most probably required.



**REFERENCE LIST OF PARTS**  
 Version: LTFT-Master BOM-2008.01.03

Note: Shaded gray areas are variables for the LTFT, depending on your model number.

POS	QTY	√	PART NUMBER	DESCRIPTION	M.O.C.	STANDARD	WETTED	STATUS	CROSS REFERENCE	NOTE
1	1		177063	Screw cap	316 SS	ASTM A351-CF8M	Yes	Obsolete	577063	
		√	577063		316 SS	ASTM A351-CF8M	Yes	Standard	None	
2	1		572302-01	Inlet housing 1.5" NPS(F)	316 SS	ASTM A351-CF8M	Yes	Non standard	None	
			177005	Inlet housing 1.5" BSP(F)	316 SS	ASTM A351-CF8M	Yes	Standard	None	
			272302	Inlet housing 1.5" NPT(F)	316 SS	ASTM A351-CF8M	Yes	Standard	None	
			477005	Inlet housing 1.5" BSP(M)	316 SS	ASTM A351-CF8M	Yes	Standard	None	
			472302	Inlet housing 1.5" NPT(M)	316 SS	ASTM A351-CF8M	Yes	Standard	None	
3	1	√	177041	Inlet o-ring	PTFE	Contact Butterworth	Yes	Standard	None	
			177041-01		Buna-N	ASTM D1418	Yes	Non standard	None	
			177041-02		Viton	Contact Butterworth	Yes	Non standard	None	
4	1		177066	Washer	Monel	ASTM A494-M35-2	Yes	Obsolete	177066-01	
		√	177066-01		316 SS	ASTM A351-CF8M	Yes	Standard	None	
5	1		5664	Guide vane assembly; type 4	See individual parts	See individual parts	Yes	Standard	None	
			5664-01	Guide vane assembly; type 4; ver. 01	See individual parts	See individual parts	Yes	Non Standard	None	
			5664-02	Guide vane assembly; type 4; ver. 02	See individual parts	See individual parts	Yes	Non Standard	None	
			5660	Guide vane assembly; type 3	See individual parts	See individual parts	Yes	Standard	None	
			5660-01	Guide vane assembly; type 3; ver. 01	See individual parts	See individual parts	Yes	Non Standard	None	
			5660-02	Guide vane assembly; type 3; ver. 02	See individual parts	See individual parts	Yes	Non Standard	None	
			5661	Guide vane assembly; type 2	See individual parts	See individual parts	Yes	Standard	None	
			5661-01	Guide vane assembly; type 2; ver. 01	See individual parts	See individual parts	Yes	Non Standard	None	
			5661-02	Guide vane assembly; type 2; ver. 02	See individual parts	See individual parts	Yes	Non Standard	None	
			6664	Guide vane assembly; type 1	See individual parts	See individual parts	Yes	Standard	None	
			6664-01	Guide vane assembly; type 1; ver. 01	See individual parts	See individual parts	Yes	Non Standard	None	
			6664-02	Guide vane assembly; type 1; ver. 02	See individual parts	See individual parts	Yes	Non Standard	None	
			5662	Guide vane assembly; type M	See individual parts	See individual parts	Yes	Standard	None	
			5662-01	Guide vane assembly; type M; ver. 01	See individual parts	See individual parts	Yes	Non Standard	None	
	5662-02	Guide vane assembly; type M; ver. 02	See individual parts	See individual parts	Yes	Non standard	None			
5.1	1		177022	Guide vane, Type 2	316 SS	ASTM A351-CF8M	Yes	Standard	None	
			177023	Guide vane, Type 3	316 SS	ASTM A351-CF8M	Yes	Standard	None	
			177104	Guide vane, Type M	316 SS	ASTM A351-CF8M	Yes	Standard	None	
			577104	Guide vane, Type 4	316 SS	ASTM A351-CF8M	Yes	Standard	None	
			677022-00	Guide vane, Type 1	316 SS	ASTM A351-CF8M	Yes	Standard	None	
5.2	1	√	177034	Groove pin	316 SS	ASTM A351-CF8M	Yes	Standard	None	
5.3	1	√	177033	Top drive shaft bushing	10% Ekanol PTFE	Contact Butterworth	Yes	Standard	None	
			177033-01	Top drive shaft bushing	Mineral filled PTFE	Contact Butterworth	Yes	Non standard	None	
			177033-02	Top drive shaft bushing	UHMW	Contact Butterworth	Yes	Non standard	None	



**REFERENCE LIST OF PARTS**  
 Version: LTFT-Master BOM-2008.01.03

Note: Shaded gray areas are variables for the LTFT, depending on your model number.

POS	QTY	√	PART NUMBER	DESCRIPTION	M.O.C.	STANDARD	WETTED	STATUS	CROSS REFERENCE	NOTE
8	1		5668	Impeller shaft assembly, Low Flow	See individual parts	See individual parts	Yes	Obsolete	8668	
			5663	Impeller shaft assembly	See individual parts	See individual parts	Yes	Obsolete	8663	
			8668	Impeller shaft assembly; type 3	See individual parts	See individual parts	Yes	Standard	None	
			8668-02	Impeller shaft assembly; type 3; ver. 02	See individual parts	See individual parts	Yes	Non standard	None	
			8663	Impeller shaft assembly; type 1	See individual parts	See individual parts	Yes	Standard	None	
			8663-02	Impeller shaft assembly; type 1; ver. 02	See individual parts	See individual parts	Yes	Non standard	None	
8.1	1		177106	Impeller, Type 3	316 SS	ASTM A351-CF8M	Yes	Obsolete	477106	
			177021	Impeller, Type 1	316 SS	ASTM A351-CF8M	Yes	Obsolete	477021	
			477106	Impeller, Type 3	316 SS	ASTM A351-CF8M	Yes	Standard	None	
			477021	Impeller, Type 1	316 SS	ASTM A351-CF8M	Yes	Standard	None	
8.2	1	√	270504	Impeller circlip	316 SS	ASTM A351-CF8M	Yes	Standard	None	
8.3	1	√	170541	Shaft key	316 SS	ASTM A351-CF8M	Yes	Standard	None	
8.4	1		177011	Shaft	17-4ph SS	ASTM A747-CCB7CU-1	Yes	Obsolete	477011	
		√	477011		17-4ph SS	ASTM A747-CCB7CU-1	Yes	Standard	None	
8.5	1	√	477044-01	Thrust pad	Carbon filled PEEK w/PTFE	Contact Butterworth	Yes	Standard	None	
			477044-02		Tungsten Carbide	Contact Butterworth	Yes	Non standard	None	
9	1	√	277603	Circlip	316 SS	ASTM A351-CF8M	Yes	Standard	None	
10	2	√	277604	H Retainer	17-4ph SS	ASTM A747-CCB7CU-1	Yes	Standard	None	
11	1	√	272604	Key, 3 mm	316 SS	ASTM A351-CF8M	Yes	Standard	None	
12	1	√	5667	Impeller housing assembly	See individual parts	See individual parts	Yes	Standard	None	
12.1	1	√	277602	Impeller housing	CD-4MCU Duplex SS	ASTM A744, A890	Yes	Standard	None	
12.2	1	√	177067	Strip	PTFE	Contact Butterworth	Yes	Standard	None	
			177067-02		UHMW	Contact Butterworth	Yes	Non standard	None	
12.3	1		177066	Washer	Monel	ASTM A494-M35-2	Yes	Obsolete	177066-01	
		√	177066-01		316 SS	ASTM A351-CF8M	Yes	Standard	None	
12.4	1	√	177062	Inlet Ring	316 SS	ASTM A351-CF8M	Yes	Standard	None	
12.5	3	√	177034	Groove pin	316 SS	ASTM A351-CF8M	Yes	Standard	None	
12.6	1	√	177007	Body bevel gear	17-4ph SS	ASTM A747-CCB7CU-1	Yes	Standard	None	
13	1	√	177038	Rotary seal	Elgiloy,10% Ekanol PTFE	Contact Butterworth	Yes	Standard	None	
			177038-01		Elgiloy, Mineral filled PTFE	Contact Butterworth	Yes	Non standard	None	
			177038-02		Elgiloy, UHMW	Contact Butterworth	Yes	Non standard	None	
14	1	√	177025	Main stem bushing	10% Ekanol PTFE	Contact Butterworth	Yes	Standard	None	
			177025-01		Mineral filled PTFE	Contact Butterworth	Yes	Non standard	None	
			177025-02		UHMW	Contact Butterworth	Yes	Non standard	None	
15	1	√	570801	Main body	CD-4MCU Duplex SS	ASTM A744, A890	Yes	Standard	None	
			370801		CD-4MCU Duplex SS	ASTM A744, A890	Yes	Obsolete	570801	



**REFERENCE LIST OF PARTS**  
 Version: LTFT-Master BOM-2008.01.03

Note: Shaded gray areas are variables for the LTFT, depending on your model number.

POS	QTY	✓	PART NUMBER	DESCRIPTION	M.O.C.	STANDARD	WETTED	STATUS	CROSS REFERENCE	NOTE
16	1	✓	477032	Nozzle thrust pad	10% Ekanol PTFE	Contact Butterworth	Yes	Standard	None	
			477032-01		Mineral filled PTFE	Contact Butterworth	Yes	Non standard	None	
			477032-02		UHMW	Contact Butterworth	Yes	Non standard	None	
			177032		10% Ekanol PTFE	Contact Butterworth	Yes	Non standard	None	
			177032-01		Mineral filled PTFE	Contact Butterworth	Yes	Non Standard	None	
			177032-02		UHMW	Contact Butterworth	Yes	Non Standard	None	
17	1	✓	477027	Nozzle bushing	10% Ekanol PTFE	Contact Butterworth	Yes	Standard	None	
			477027-01		Mineral filled PTFE	Contact Butterworth	Yes	Non standard	None	
			477027-02		UHMW	Contact Butterworth	Yes	Non standard	None	
			177027		10% Ekanol PTFE	Contact Butterworth	Yes	Non standard	None	
			177027-01		Mineral filled PTFE	Contact Butterworth	Yes	Non standard	None	
			177027-02		UHMW	Contact Butterworth	Yes	Non standard	None	
18	1	✓	177008	Nozzle bevel gear	17-4ph SS	ASTM A747-CCB7CU-1	Yes	Standard	None	
19	1	✓	477032	Nozzle thrust pad	10% Ekanol PTFE	Contact Butterworth	Yes	Standard	None	
			477032-01		Mineral filled PTFE	Contact Butterworth	Yes	Non standard	None	
			477032-02		UHMW	Contact Butterworth	Yes	Non standard	None	
			177032		10% Ekanol PTFE	Contact Butterworth	Yes	Non standard	None	
			177032-01		Mineral filled PTFE	Contact Butterworth	Yes	Non Standard	None	
			177032-02		UHMW	Contact Butterworth	Yes	Non Standard	None	
20	1	✓	477027	Nozzle bushing	10% Ekanol PTFE	Contact Butterworth	Yes	Standard	None	
			477027-01		Mineral filled PTFE	Contact Butterworth	Yes	Non standard	None	
			477027-02		UHMW	Contact Butterworth	Yes	Non standard	None	
			177027		10% Ekanol PTFE	Contact Butterworth	Yes	Non standard	None	
			177027-01		Mineral filled PTFE	Contact Butterworth	Yes	Non standard	None	
			177027-02		UHMW	Contact Butterworth	Yes	Non standard	None	
21	1	✓	177039	Rotary seal	Elgiloy,10% Ekanol PTFE	Contact Butterworth	Yes	Standard	None	
			177039-01		Elgiloy, Mineral filled PTFE	Contact Butterworth	Yes	Non standard	None	
			177039-02		Elgiloy, UHMW	Contact Butterworth	Yes	Non standard	None	
22	2	✓	270834	Nozzle o-ring	PTFE	Contact Butterworth	Yes	Standard	None	
			177071		EDPM	Contact Butterworth	Yes	Non standard	None	
23	2		177018	Stream straightener			Yes	Standard	None	
24	2		177061	Nozzle Tip 6MM	316 SS	ASTM A351-CF8M	Yes	Standard	None	
			177060	Nozzle Tip 8MM	316 SS	ASTM A351-CF8M	Yes	Standard	None	
			177059	Nozzle Tip 10MM	316 SS	ASTM A351-CF8M	Yes	Standard	None	
			177058	Nozzle Tip 12MM	316 SS	ASTM A351-CF8M	Yes	Standard	None	
25	1	✓	177002	Nozzle body	316 SS	ASTM A351-CF8M	Yes	Standard	None	



**REFERENCE LIST OF PARTS**  
 Version: LTFT-Master BOM-2008.01.03

Note: Shaded gray areas are variables for the LTFT, depending on your model number.

POS	QTY	✓	PART NUMBER	DESCRIPTION	M.O.C.	STANDARD	WETTED	STATUS	CROSS REFERENCE	NOTE
26	1	✓	477032	Nozzle thrust pad	10% Ekanol PTFE	Contact Butterworth	Yes	Standard	None	
			477032-01		Mineral filled PTFE	Contact Butterworth	Yes	Non standard	None	
			477032-02		UHMW	Contact Butterworth	Yes	Non standard	None	
			177032		10% Ekanol PTFE	Contact Butterworth	Yes	Non standard	None	
			177032-01		Mineral filled PTFE	Contact Butterworth	Yes	Non Standard	None	
			177032-02		UHMW	Contact Butterworth	Yes	Non Standard	None	
27	1	✓	177039	Rotary seal	Elgiloy,10% Ekanol PTFE	Contact Butterworth	Yes	Standard	None	
			177039-01		Elgiloy, Mineral filled PTFE	Contact Butterworth	Yes	Non standard	None	
			177039-02		Elgiloy, UHMW	Contact Butterworth	Yes	Non standard	None	
28	1	✓	477019	Nozzle cap	316 SS	ASTM A351-CF8M	Yes	Standard		
			177019		316 SS	ASTM A351-CF8M	Yes	Non standard	None	
29	1	✓	177025	Main stem bushing	10% Ekanol PTFE	Contact Butterworth	Yes	Standard	None	
			177025-01		Mineral filled PTFE	Contact Butterworth	Yes	Non standard	None	
			177025-02		UHMW	Contact Butterworth	Yes	Non standard	None	
30	1	✓	377702	Large race	17-4ph SS	ASTM A747-CCB7CU-1	Yes	Standard		
31	1	✓	7006	Thrust retainer assembly	Tefzel w/ ceramic balls	Contact Butterworth		Yes	Standard	
			7006-01		Tefzel w/ 316L SS balls	Contact Butterworth		Yes	Non Standard	
			7006-02		PEEK w/ ceramic balls	Contact Butterworth		Yes	Non Standard	
			7006-03		PEEK w/ 316L SS balls	Contact Butterworth		Yes	Non Standard	
			377705		Tercite A w/ ceramic balls	Contact Butterworth	Yes	Obsolete	7006	
32	1		7666	Main stem assembly	See individual parts	See individual parts	Yes	Obsolete	7666-01	
		✓	7666-01	Main stem assembly; ver. 01	See individual parts	See individual parts	Yes	Standard	None	
			7666-02	Main stem assembly; ver. 02	See individual parts	See individual parts	Yes	Non Standard	None	
32.1	1	✓	377702	Large race	17-4ph SS	ASTM A747-CCB7CU-1	Yes	Standard	None	
32.2	1	✓	177024	Drive shaft bushing	10% Ekanol PTFE	Contact Butterworth	Yes	Standard	None	
			177024-01		Mineral filled PTFE	Contact Butterworth	Yes	Non standard	None	
			177024-02		UHMW	Contact Butterworth	Yes	Non standard	None	
32.3	1		377601	Main stem	CD4-Mcu duplex SS	ASTM A744, A890	Yes	Obsolete	377601-01	
			377601 -01	Main stem assembly (Includes positions 32.3a, 32.3b, & 32.3c)	CD4-Mcu duplex SS	ASTM A744, A890	Yes	Standard	None	
32.3a	1	✓	477600	Main stem shaft	316 SS	ASTM A351-CF8M		Standard		
32.3b	3	✓	177034	Pin	316 SS	ASTM A351-CF8M		Standard	177034	
32.3c	1		477601	Main stem gear	17-4ph SS	ASTM A747-CCB7CU-1		Standard	None	
		✓	477601-01		CD4-Mcu duplex SS	ASTM A744, A890		Standard	None	
32.4	2	✓	177024	Drive shaft bushing	10% Ekanol PTFE	Contact Butterworth	Yes	Standard	None	
			177024-01		Mineral filled PTFE	Contact Butterworth	Yes	Non standard	None	
			177024-02		UHMW	Contact Butterworth	Yes	Non standard	None	
36	1	✓	177030	Carrier thrust pad	10% Ekanol PTFE	Contact Butterworth	Yes	Standard	None	
			177030-01		Mineral filled PTFE	Contact Butterworth	Yes	Non standard	None	
			177030-02		UHMW	Contact Butterworth	Yes	Non standard	None	



**REFERENCE LIST OF PARTS**  
 Version: LTFT-Master BOM-2008.01.03

Note: Shaded gray areas are variables for the LTFT, depending on your model number.

POS	QTY	√	PART NUMBER	DESCRIPTION	M.O.C.	STANDARD	WETTED	STATUS	CROSS REFERENCE	NOTE
37	1	√	7665	LTFT gearbox assembly	See individual parts	See individual parts	Yes	Standard	None	
			7665-01		See individual parts	See individual parts	Yes	Non standard	None	
			7665-02		See individual parts	See individual parts	Yes	Non standard	None	
37.1	1	√	177034	Groove pin	316 SS	ASTM A351-CF8M	Yes	Standard	None	
37.2	1	√	370302	Internal gear	17-4ph SS	ASTM A747-CCB7CU-1	Yes	Standard	None	
37.3	1	√	177026	Carrier bushing	10% Ekanol PTFE	Contact Butterworth	Yes	Standard	None	
			177026-01		Mineral filled PTFE	Contact Butterworth	Yes	Non standard	None	
			177026-02		UHMW	Contact Butterworth	Yes	Non standard	None	
37.4	1	√	377009	Carrier, Flow Through	316 SS	ASTM A351-CF8M	Yes	Standard	None	
37.5	1		7659	Planet gear assembly	See individual parts	See individual parts	Yes	Standard	None	
			7659-02	Planet gear assembly; ver. 02	See individual parts	See individual parts	Yes	Non Standard	None	
37.5a	2	√	177028	Planet gear bushing	Carbon filled PEEK w/PTFE	Contact Butterworth	Yes	Standard	None	
			177028-02		Carbon filled PEEK	Contact Butterworth	Yes	Non standard	None	
37.5b	2	√	7659A	Planet gear	17-4ph SS	ASTM A747-CCB7CU-1	Yes	Standard	None	
			377102	Planet gear	17-4ph SS		Yes	Obsolete	7659A	√
			377014	Star gear	17-4ph SS		Yes	Obsolete	7659A	√
37.6	4	√	377707	Race	17-4ph SS	ASTM A747-CCB7CU-1	Yes	Standard	None	
37.7	2		377706	Thrust retainer assy	Tefzel w/ 316 SS balls	Contact Butterworth	Yes	Standard	None	
			377706-02		Nylon w/ 440c SS balls	Contact Butterworth	Yes	Non standard	None	
37.8	2		377020	Gear shaft	Tungsten Carbide	Contact Butterworth	Yes	Obsolete	377020-01	
		√	377020-01		MP35N	ASTM F562	Yes	Standard	None	
37.9	1	√	377702	Large race	17-4ph SS	ASTM A747-CCB7CU-1	Yes	Standard	None	
37.10	2	√	270506	Pin	316 SS	ASTM A351-CF8M	Yes	Standard	None	
38	1	√	177035	Circlip	316 SS	ASTM A351-CF8M	Yes	Standard		
39	1		177101	Drive gear	17-4ph SS	ASTM A747-CCB7CU-1	Yes	Obsolete	377101	
	1	√	377101		17-4ph SS	ASTM A747-CCB7CU-1	Yes	Standard		
40	1	√	7006	Thrust retainer assembly	Tefzel w/ ceramic balls	Contact Butterworth	Yes	Standard		
			7006-01		Tefzel w/ 316L SS balls	Contact Butterworth	Yes	Non standard		
			7006-02		PEEK w/ ceramic balls	Contact Butterworth	Yes	Non standard		
			7006-03		PEEK w/ 316L SS balls	Contact Butterworth	Yes	Non standard		
41	1		6657	End plate assembly	See individual parts	See individual parts	Yes	Non standard	None	
		√	7657		See individual parts	See individual parts	Yes	Standard	None	
41.1	1	√	377702	Large race	17-4ph SS	ASTM A747-CCB7CU-1	Yes	Standard	None	
41.2	1		177044	End plate thrust pad	Tungsten Carbide	Contact Butterworth	Yes	Non standard	None	
		√	177044-01		MP35N	ASTM F562	Yes	Standard	None	
41.3	1	√	370807	End plate, Flow Through	316 SS	ASTM A351-CF8M	Yes	Standard	None	

### EXPLODED VIEW DRAWING

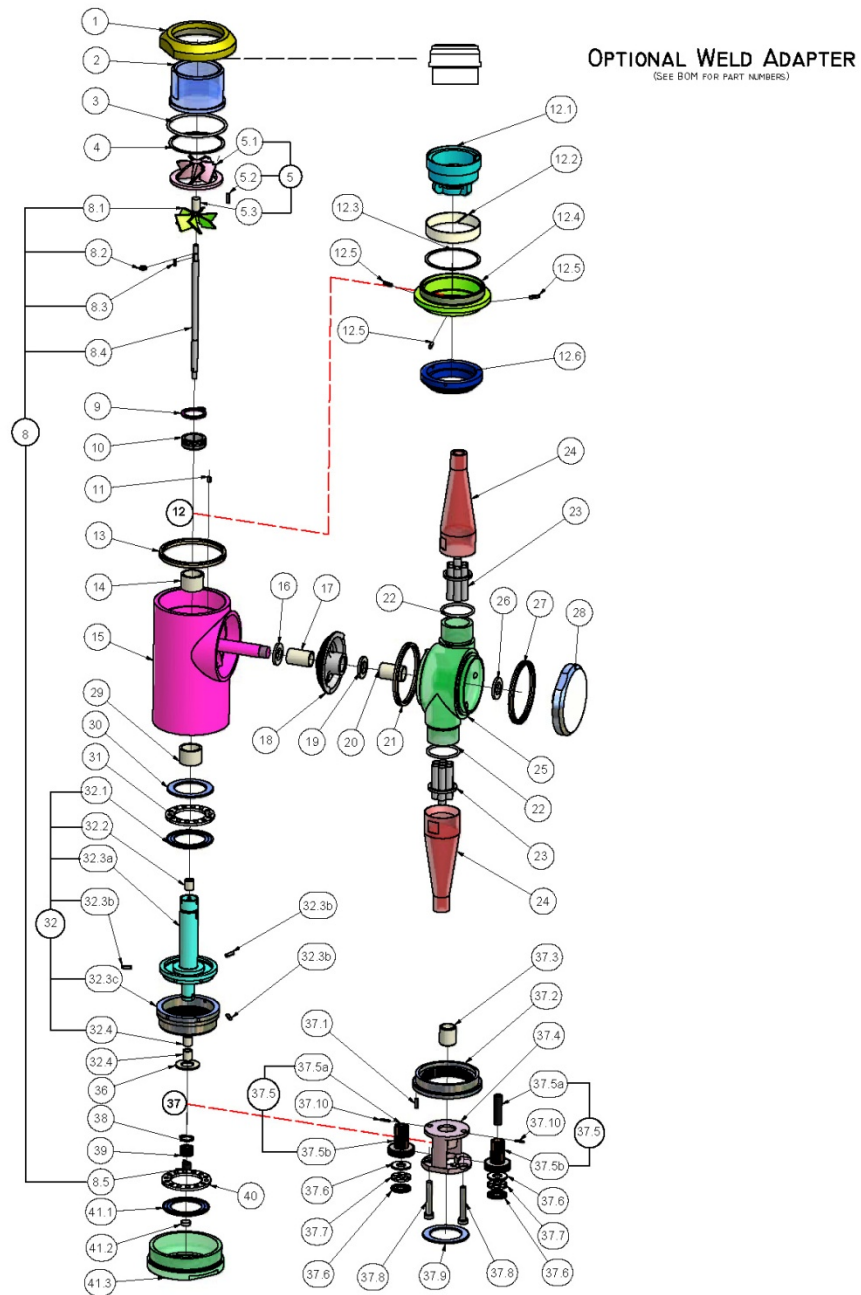

Figure 31

**CROSSECTIONAL DRAWING**

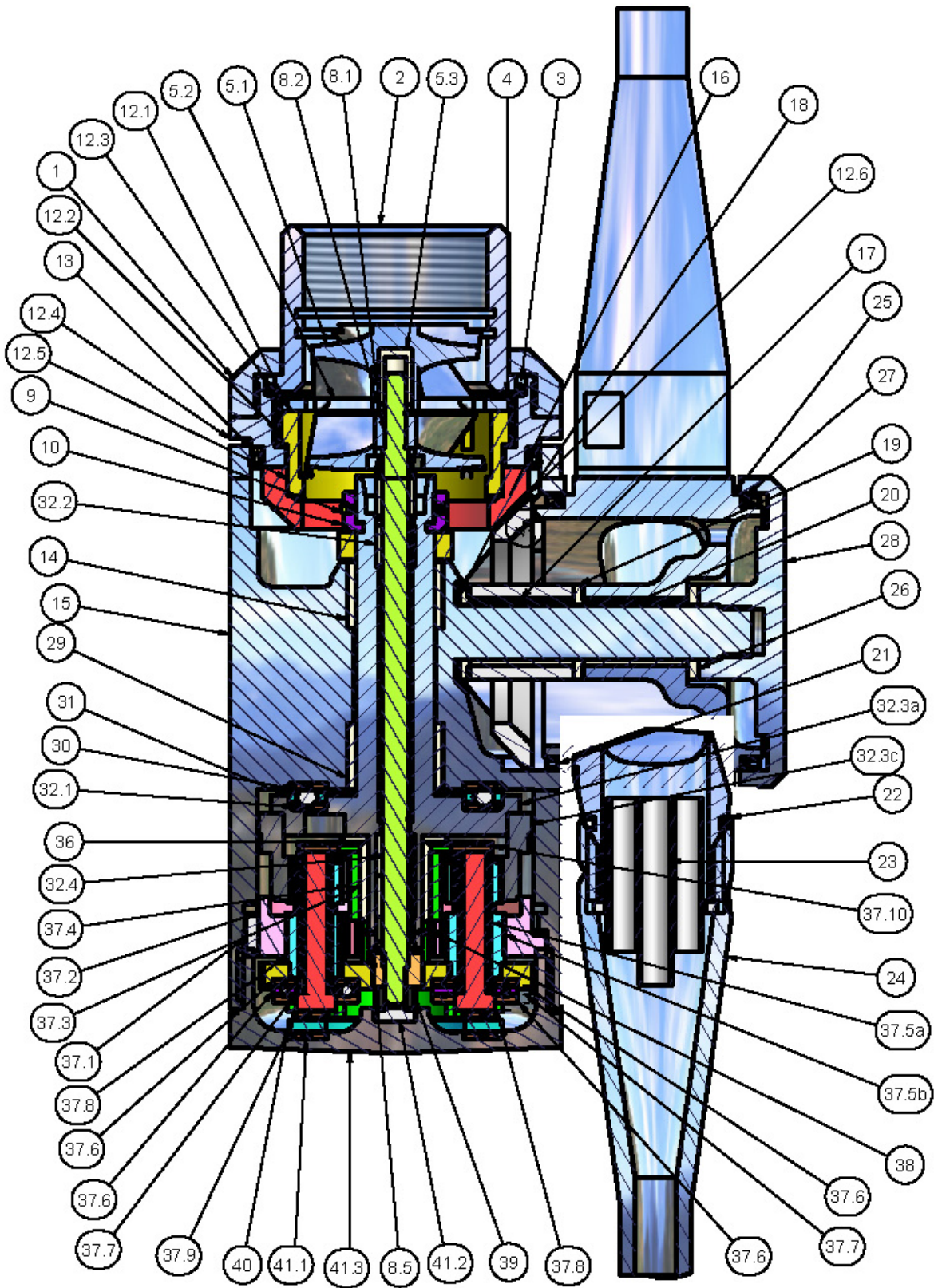

Figure 32



## STANDARD SPARE PART KIT

Spare Part Kit Number: LTSPK-LTFT-300

*Recommended at  $\leq$  400 hours of operation.*

Position	Part No.	Description	Quantity
8.3	170541	Key; 2mm x 2mm x 6mm	1
32.2; 32.4(2)	177024	Drive shaft bushing	3
17; 20	477027	Nozzle bearing	2
5.2(1); 12.5(3);32.3c(3); 37.1(1)	177034	Pin	8
38	177035	Circlip; external	1
13	177038	Rotary seal	1
21; 27	177039	Rotary seal	2
8.2	270504	Circlip	1
37.10	270506	Groove pin type B	2
11	272604	Key; 3mm x 3mm x 6mm	1

Spare Part Kit / Gears: LTSPK-LTFT-G

*Recommended at  $\leq$  1200 hours of operation.*

Position	Part No.	Description	Quantity
39	377101	Drive gear	1
37.2	370302	Ring gear	1
37.5	7659	Planet gear assembly	2
12.6	177007	Bevel gear (65)	1
18	177008	Bevel gear (63)	1

It is suggested that you possess the correct tools before performing repairs on the LT machine. For a list of tools and tool kit part number see page 26.



Operators Manual Model : LTFT  
Manual No. : 202.2008.01.14  
Release Date : JUNE 1, 2008

## HOW TO ORDER SPARE PARTS AND WARRANTY CLAIM PROCEDURE

### Ordering Spare Parts

To order spare parts, you will need to identify the serial number of your tank cleaning machine and correlate that to the manual that was issued at the time of purchase. The parts that were used to construct your machine will be indicated by a  $\checkmark$  in the  $\checkmark$  column of the reference list of parts beginning on page 29. If you are unable to find the manuals issued at the time of purchase, you can call the Butterworth® Sales desk and give them your machine serial numbers requesting that they identify the appropriate manual and to send you a copy. Our manuals are all in digital format and can be easily emailed to you for printing at your location.

When ordering, indicate the part number for the checked ( $\checkmark$ ) position on the reference list of parts and the quantity required.

### Warranty Claim Procedure

In the event of a malfunction of the equipment supplied under this manual and it is felt by the customer that it could be claimed under the terms of our Warranty, you will need to send the unit to Butterworth® for review and evaluation. A copy of our Warranty can be reviewed on page 40

To send in a unit for warranty review, you will need to call the Butterworth® Sales Desk and advise the associate that you wish to return a machine(s) for warranty review. They will issue a Returned Goods Number for tracking your equipment once received by our company. This number must be included in your shipping documents else there will be a delay in evaluating this equipment. It is also necessary to complete the "**Error! Reference source not found.**" located on page **Error! Bookmark not defined.** in this manual. This report must be completed and returned with the equipment for the warranty claim process to commence. Be sure to affix the Returned Goods Number given to you by the Sales Desk in the appropriate box of the **Error! Reference source not found.**





## WARRANTY CLAIM REPORT

Returned Goods Number: \_\_\_\_\_

**Contact Information:**

Contact Name: \_\_\_\_\_ Contact Phone Number: \_\_\_\_\_  
 Contact Fax Number: \_\_\_\_\_ Contact Email Address: \_\_\_\_\_

Machine Model Number: \_\_\_\_\_ Serial No: \_\_\_\_\_

Configuration: Nozzles \_\_\_\_\_ x Ø \_\_\_\_\_ mm Impeller Type: \_\_\_\_\_ Guide Vane Type: \_\_\_\_\_

**Operating Conditions:**

- a) Inlet pressure at tank cleaning machine: \_\_\_\_\_ (PSI)
- b) Type of Valve in inlet line:  Ball Valve  Butterfly Valve  Gate Valve  Other: \_\_\_\_\_
- c) Can hydraulic shock be disregarded?  Yes  No
- d) Ramp up time to full pressure on the tank cleaning machine occurs over how many seconds: \_\_\_\_\_
- e) Was inlet line flushed before installation of tank cleaner?  Yes  No
- f) Working hours before failure: \_\_\_\_\_ hours.
- g) What is the micron filtration on the media (washing solution) prior to entering the machine: \_\_\_\_\_
- h) Is the tank cleaning machine flushed with clean water or other clean fluid after cleaning has been finished.  Yes  No
- i) Is steam injection being used for heating:  Yes  No
- j) Is the tank cleaning machine submerged in the tank product or any other fluid while in use:  Yes  No
  - 1.) If yes, describe the material and conditions: \_\_\_\_\_
- k) Chemicals and conditions that the tank cleaning machine is subjected to whether at rest or in operation: \_\_\_\_\_

**Cleaning Recipe:**

Cleaning Media and Concentration	Temp (Indicate F or C)	Time (Minutes)	Recirculation?
			<input type="checkbox"/> Yes <input type="checkbox"/> No
			<input type="checkbox"/> Yes <input type="checkbox"/> No
			<input type="checkbox"/> Yes <input type="checkbox"/> No
			<input type="checkbox"/> Yes <input type="checkbox"/> No

Other Comments: \_\_\_\_\_  
 \_\_\_\_\_  
 \_\_\_\_\_

Date: \_\_\_\_\_ Signature: \_\_\_\_\_



Operators Manual Model : LTFT  
Manual No. : 202.2008.01.14  
Release Date : JUNE 1, 2008

## GENERAL WARRANTY

Products supplied under the Agreement will be free from defects in materials and workmanship. The Company's sole and exclusive liability shall be its option either to repair or replace F.O.B. point of shipment, any defective Products, or to accept return , transportation prepaid, of such Products and refund the purchase price; in either case, provided that written notice of s u c h defect is given to the Company within twelve (12) months from date of shipment to the customer, the product is found by the Company to have been installed and/or operated in accordance with the Company's instructions, that no repairs, alterations or replacements have been made by another without the Company's written approval. In no event shall the aggregate liability of the Company in connection with breach of any warranty or warranties exceed the purchase price p aid for the Product here under. The Company may at it s option, require the return of any Products, transportation and duties prepaid to establish any claim of defect made by the customer. Unless otherwise agreed in writing the Company will not accept and shall have no responsibility for the Products returned without its prior written consent. **THE COMPANY MAKES NO OTHER WARRANTY OF ANYKIND, EXPRESSED OR IMPLIED, INCLUDING, BUT NOT LIMITED TO, THE IMPLIED WARRANTY OF MERCHANTABILITY OR FITNESS FOR ANY PARTICULAR PURPOSE. THE COMPANY HEREBY EXPRESSLY DISCLAIMS ANY AND ALL EXPRESS OR IMPLIED WARRANTY OF MERCHANTABILITY OR FITNESS.**



Operators Manual Model : LTFT  
Manual No. : 202.2008.01.14  
Release Date : JUNE 1, 2008

## INDEX

### Drawing

Top assembly ..... 15  
Gear Sub-Assembly .....23

### Maintenance & Repair

Preventive maintenance ..... 13  
Service card ..... 38

### Performance Curves

Pressure, flow, jet-length .....9

### Table of Contents.....2

#### Technical Data

Cleaning pattern construction .....5  
Dimensions and weight..... 8  
Standard configurations ..... 6

#### Warranty

Claim Report..... 39